



**TRÖSTEN**

## Installation & User's Manual

---

### Sunpro Series

Monoblock Unit

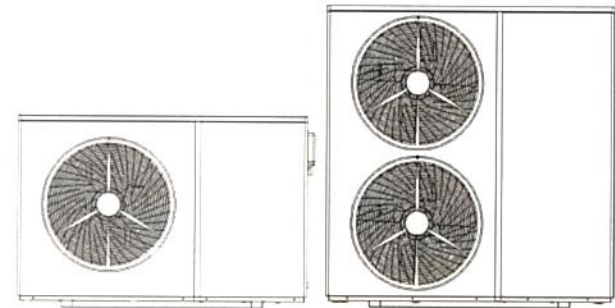

T119-01-10-00884 A



**IMPORTANT NOTE:**

Thank you very much for purchasing our product. Before using your unit, please read this manual carefully and keep it for future reference.

CONTENTS

- 1. FOREWORD ..... 1
  - 1.1. Read the Manual Before Operation ..... 1
  - 1.2. The Symbol Description of the Device ..... 6
  - 1.3. Statement ..... 6
  - 1.4. Safety Factors ..... 7
  - 1.5. Accessories ..... 9
- 2.OVERVIEW OF THE UNIT ..... 10
  - 2.1. Dimensions of the Unit ..... 10
  - 2.2. Main Parts of the Unit ..... 13
  - 2.3. Parameter of the Unit ..... 19
- 3.INSTALLATION AND CONNECTION ..... 24
  - 3.1. Transportation ..... 24
  - 3.2. Installation Instruction ..... 24
    - 3.2.1. Pre-requirements ..... 24
    - 3.2.2. Location and Space ..... 24
    - 3.2.3. Installation Layout ..... 28
    - 3.2.4. Electrical Installation ..... 33
    - 3.2.5. Electrical Connection ..... 33
  - 3.3. Trial After Installation ..... 43
    - 3.3.1. Inspection Before Trial Running ..... 43
    - 3.3.2. Trial Running ..... 43
- 4. MAINTENANCE AND WINTERIZATION ..... 44
  - 4.1. Maintenance ..... 44
  - 4.2. Winterizing ..... 44
- 5. REMOVAL PROCEDURES FOR OUTDOOR UNITS ..... 45
  - 5.1. Removal Instructions for Outdoor Panels ..... 45

## 1. FOREWORD

### 1.1. Read the Manual Before Operation

#### **WARNING**

Do not use means other than those recommended by the manufacturer to accelerate the defrosting process or to clean. The appliance shall be stored in a room with no ignition sources (for example: open flames, gas appliance, or electric heater).

Do not pierce or burn.

Be aware that refrigerants may not contain an odour.

#### **Initial safety checks shall include:**

- ① Capacitors are discharged: this shall be done in a safe manner to avoid the possibility of sparking.
- ② No live electrical components and wiring are exposed while charging, recovering, or purging the system.
- ③ There is continuity of earth bonding.

#### **Checks to the area**

Prior to beginning work on systems containing flammable refrigerants, safety checks are necessary to ensure that the risk of fire is minimized. For repair to the refrigerating system, the following precautions shall be complied with prior to conducting work on the system.

#### **Work procedure**

Work shall be undertaken under a controlled procedure so as to minimize the risk of flammable gas or vapor being present while the work is being performed.

#### **General work area**

All maintenance staff and others working in the local area shall be instructed on the nature of the work being carried out. Work in confined spaces shall be avoided.

#### **Checking for the presence of refrigerant**

The area shall be checked with an appropriate refrigerant detector prior to and during work, to ensure the technician is aware of potentially flammable atmospheres. Ensure that the leak detection equipment being used is suitable for use with flammable refrigerants, i.e. non-sparking, adequately sealed, or intrinsically safe.

#### **Presence of a fire extinguisher**

If any hot work is to be conducted on the refrigerating equipment or any associated parts, appropriate fire extinguishing equipment shall be available to hand. Have a dry powder or CO2 fire extinguisher adjacent to the charging area.



### **No ignition sources**

No person carrying out work in relation to a refrigeration system that involves exposing any pipework that contains or has contained flammable refrigerant shall use any sources of ignition in such a manner that it may lead to the risk of fire or explosion. All possible ignition sources, including cigarette smoking, should be kept sufficiently far away from the site of installation, repairing, removal, and disposal, during which flammable refrigerant can possibly be released to the surrounding space. Prior to work taking place, the area around the equipment is to be surveyed to make sure that there are no flammable hazards or ignition risks. "No Smoking" signs shall be displayed.

### **Ventilated area**

Ensure that the area is in the open or that it is adequately ventilated before breaking into the system or conducting any hot work. A degree of ventilation shall continue during the period that the work is carried out. The ventilation should safely disperse any released refrigerant and preferably expel it externally into the atmosphere.

### **Checks to the refrigeration equipment**

Where electrical components are being changed, they shall be fit for the purpose and to the correct specification. At all times the manufacturer's maintenance and service guidelines shall be followed. If in doubt consult the manufacturer's technical department for assistance. The following checks shall be applied to installations using flammable refrigerants:

- ① The charge size is in accordance with the room size within which the refrigerant containing parts are installed;
- ② The ventilation machinery and outlets are operating adequately and are not obstructed;
- ③ If an indirect refrigerating circuit is being used, the secondary circuit shall be checked for the presence of refrigerant;
- ④ Marking of the equipment continues to be visible and legible. Markings and signs that are illegible shall be corrected;
- ⑤ Refrigeration pipes or components are installed in a position where they are unlikely to be exposed to any substance which may corrode refrigerant containing components unless the components are constructed of materials that are inherently resistant to being corroded or are suitably protected against being so corroded.

### **Repairs to sealed components**

**DD.5.1** During repairs to sealed components, all electrical supplies shall be disconnected from the equipment being worked upon prior to any removal of sealed covers, etc. If it is necessary to have an electrical supply to equipment during servicing, then a permanently operating form of leak detection shall be located at the most critical point to warn of a potentially hazardous situation.

**DD.5.2** Particular attention shall be paid to the following to ensure that by working on electrical components, the casing is not altered in such a way that the level of protection is affected. This shall include damage to cables, excessive number of connections, terminals not made to original specification, damage to seals, incorrect fitting of glands, etc.

Ensure that the apparatus is mounted securely.

Ensure that seals or sealing materials have not degraded to the point that they no longer serve the purpose of preventing the ingress of flammable atmospheres. Replacement parts shall be in accordance with the manufacturer's specifications.

### **Repair to intrinsically safe components**

Do not apply any permanent inductive or capacitance loads to the circuit without ensuring that this will not exceed the permissible voltage and current permitted for the equipment in use. Intrinsically safe components are the only types that can be worked on while live in the presence of a flammable atmosphere. The test apparatus shall be at the correct rating.

Replace components only with parts specified by the manufacturer. Other parts may result in the ignition of refrigerant in the atmosphere from a leak.

**NOTE** The use of silicon sealant can inhibit the effectiveness of some types of leak detection equipment.

Intrinsically safe components do not have to be isolated prior to working on them.

### **Cabling**

Check that cabling will not be subject to wear, corrosion, excessive pressure, vibration, sharp edges, or any other adverse environmental effects. The check shall also take into account the effects of aging or continual vibration from sources such as compressors or fans.

### **Detection of flammable refrigerants**

Under no circumstances shall potentially sources of ignition be used in the searching for or detection of refrigerant leaks. A halide torch (or any other detector using a naked flame) shall not be used.

### **Leak detection methods**

The following leak detection methods are deemed acceptable for systems containing flammable refrigerants.

Electronic leak detectors shall be used to detect flammable refrigerants, but the sensitivity may not be adequate or may need re-calibration. (Detection equipment shall be calibrated in a refrigerant-free area.) Ensure that the detector is not a potential source of ignition and is suitable for the refrigerant used. Leak detection equipment shall be set at a percentage of the LFL of the refrigerant and shall be calibrated to the refrigerant employed and the appropriate percentage of gas (25 % maximum) is confirmed.

Leak detection fluids are suitable for use with most refrigerants but the use of detergents containing chlorine shall be avoided as the chlorine may react with the refrigerant and corrode the copper pipework.

If a leak is suspected, all naked flames shall be removed/extinguished.

If leakage of refrigerant is found which requires brazing, all the refrigerants shall be recovered from the system, or isolated (by means of shut-off valves) in a part of the system remote from the leak. Oxygen free nitrogen (OFN) shall then be purged through the system both before and during the brazing process.



### Removal and evacuation

When breaking into the refrigerant circuit to make repairs – or for any other purpose – conventional procedures shall be used. However, it is important that best practice is followed since flammability is a consideration. The following procedure shall be adhered to:

- ① Remove refrigerant
- ② Purge the circuit with inert gas
- ③ Evacuate
- ④ Purge again with inert gas
- ⑤ Open the circuit by cutting or brazing

The refrigerant charge shall be recovered into the correct recovery cylinders. The system shall be "flushed" with OFN to render the unit safe. This process may need to be repeated several times. Compressed air or oxygen shall not be used for this task.

Flushing shall be achieved by breaking the vacuum in the system with OFN and continuing to fill until the working pressure is achieved, then venting to the atmosphere, and finally pulling down to a vacuum. This process shall be repeated until no refrigerant is within the system. When the final OFN charge is used, the system shall be vented down to the atmospheric pressure to enable work to take place. This operation is vital if brazing operations on the pipework are to take place.

Ensure that the outlet for the vacuum pump is not close to any ignition sources and there is ventilation available.

### Charging procedures

In addition to conventional charging procedures, the following requirements shall be followed:

- ① Ensure that contamination of different refrigerants does not occur when using charging equipment. Hoses or lines shall be as short as possible to minimize the amount of refrigerant contained in them. Cylinders shall be kept upright.
- ② Ensure that the refrigeration system is earthed prior to charging the system with refrigerant.
- ③ Label the system when charging is complete (if not already).
- ④ Extreme care shall be taken not to overfill the refrigeration system. Prior to recharging the system, it shall be pressure tested with OFN. The system shall be leak tested on completion of charging prior to commissioning. A follow-up leak test shall be carried out prior to leaving the site.

### Decommissioning

Before carrying out this procedure, it is essential that the technician is completely familiar with the equipment and all its detail. It is recommended good practice that all refrigerants are recovered safely. Prior to the task being carried out, an oil and refrigerant sample shall be taken in case analysis is required prior to re-use of reclaimed refrigerant. It is essential that electrical power is available before the task is commenced.

- ① Become familiar with the equipment and its operation.

- ② Isolate system electrically.
- ③ Before attempting the procedure ensure that:
  - Mechanical handling equipment is available, if required, for handling refrigerant cylinders.
  - All personal protective equipment is available and being used correctly.
  - The recovery process is supervised at all times by a competent person.
  - Recovery equipment and cylinders conform to the appropriate standards.
- ④ Pump down refrigerant system, if possible.
- ⑤ If a vacuum is not possible, make a manifold so that refrigerant can be removed from various parts of the system.
- ⑥ Make sure that the cylinder is situated on the scales before recovery takes place.
- ⑦ Start the recovery machine and operate following the manufacturer's instructions.
- ⑧ Do not overfill cylinders. (No more than 80 % volume liquid charge).
- ⑨ Do not exceed the maximum working pressure of the cylinder, even temporarily.
- ⑩ When the cylinders have been filled correctly and the process completed, make sure that the cylinders and the equipment are removed from the site promptly and all isolation valves on the equipment are closed off.
- ⑪ Recovered refrigerant shall not be charged into another refrigeration system unless it has been cleaned and checked.

### Labeling

Equipment shall be labeled stating that it has been decommissioned and emptied of refrigerant. The label shall be dated and signed. Ensure that there are labels on the equipment stating the equipment contains flammable refrigerant.

### Recovery

When removing refrigerants from a system, either for servicing or decommissioning, it is recommended good practice that all refrigerants are removed safely. When transferring refrigerant into cylinders, ensure that only appropriate refrigerant recovery cylinders are employed. Ensure that the correct number of cylinders for holding the total system charge is available. All cylinders to be used are designated for the recovered refrigerant and labeled for that refrigerant (i.e. special cylinders for the recovery of refrigerant). Cylinders shall be complete with a pressure relief valve and associated shut-off valves in good working order. Empty recovery cylinders are evacuated and, if possible, cooled before recovery occurs. The recovery equipment shall be in good working order with a set of instructions concerning the equipment that is at hand and shall be suitable for the recovery of flammable refrigerants.

In addition, a set of calibrated weighing scales shall be available and in good working order. Hoses shall be complete with leak-free disconnect couplings and in good condition. Before using the recovery machine, check that it is in satisfactory working order, has been properly maintained, and that any associated electrical components are sealed to prevent ignition in the event of a refrigerant release. Consult the manufacturer if in doubt.

The recovered refrigerant shall be returned to the refrigerant supplier in the correct recovery cylinder, and the relevant Waste Transfer Note arranged. Do not mix refrigerants in recovery





units and especially not in cylinders.

If compressors or compressor oils are to be removed, ensure that they have been evacuated to an acceptable level to make certain that flammable refrigerant does not remain within the lubricant. The evacuation process shall be carried out prior to returning the compressor to the suppliers. Only electric heating to the compressor body shall be employed to accelerate this process. When oil is drained from a system, it shall be carried out safely.

## 1.2. The Symbol Description of the Device

The precautions listed here are divided into the following types. They are quite important, so be sure to follow them carefully.

Explanation of symbols displayed on the indoor unit or outdoor unit

Symbols	Meaning	Description
	<b>WARNING</b>	The symbol shows that this appliance uses a flammable refrigerant. If the refrigerant is leaked and exposed to an external ignition source, there is a risk of fire.
	<b>WARNING</b>	The symbol shows that this appliance uses a low burning velocity material. Please keep away from the fire source.
	<b>CAUTION</b>	This symbol shows that the operation manual should be read carefully.
	<b>CAUTION</b>	This symbol shows that service personnel should be handling this equipment with reference to the installation manual.
	<b>CAUTION</b>	This symbol shows that information is available such as the operating manual or installation manual.

## 1.3. Statement

To keep users under safe working conditions and property safety, please follow the instructions below:

- ① Wrong operation may result in injury or damage.
- ② Please install the unit in compliance with local laws, regulations, and standards.
- ③ Confirm power voltage and frequency.
- ④ The unit is only used with grounding sockets.
- ⑤ Independent switch must be offered with the unit.

## 1.4. Safety Factors

The following safety factors need to be considered:

- ① Please read the following warnings before installation.
- ② Be sure to check the details that need attention, including safety factors.
- ③ After reading the installation instructions, be sure to save them for future reference.

### WARNING

Make sure that the unit is installed safely and reliably.

- If the unit is not secure or not installed, it may cause damage. The minimum support weight required for installation is 21g/mm<sup>2</sup>.

- If the unit was installed in a closed area or limited space, please consider the size of the room and ventilation to prevent suffocation caused by refrigerant leakage.

- ① Use a specific wire and fasten it to the terminal block so that the connection will prevent pressure from being applied to parts.

- ② Wrong wiring will cause a fire.

Please connect the power wire accurately according to the wiring diagram on the manual to avoid burnout of the unit or fire.

- ③ Be sure to use the correct material during installation.

Wrong parts or wrong materials may result in fire, electric shock, or unit falling.

- ④ Install on the ground safely, please read installation instructions.

Improper installation may result in fire, electric shock, falling of the unit, or water leaking.

- ⑤ Use professional tools for doing electrical work.

If power supply capacity is insufficient or the circuit is not completed, it may cause fire or electric shock.

- ⑥ The unit must have a grounding device.

If the power supply does not have a grounding device, be sure not to connect the unit.

- ⑦ The unit should be only removed and repaired by a professional technician.

Improper movement or maintenance of the unit may cause water leakage, electric shock, or fire. Please find a professional technician to do it.

- ⑧ Don't unplug or plug power during operation. It may cause fire or electric shock.

- ⑨ Don't touch or operate the unit when your hands are wet. It may cause fire or electric shock.

- ⑩ Don't place heaters or other electrical appliances near the power wire. It may cause fire or electric shock.





- ⑪ The water must not be poured directly from the unit. Do not let water permeate into the electrical components.



**⚠ WARNING**

- ① Do not install the unit in a location where there may be flammable gas.
- ② If there is flammable gas around the unit, it will cause an explosion.  
According to the instruction to carry out drainage system and pipeline work. If the drainage system or pipeline is defective, water leakage will occur. And it should be disposed of immediately to prevent other household products from getting wet and damaged.
- ③ Do not clean the unit while the power is on. Turn off power before cleaning the unit. If not it may result in injury from a high-speed fan or electric shock.
- ④ Stop operating the unit once there is a problem or a fault code.  
Please turn off the power and stop running the unit. Otherwise, it may cause electric shock or fire.
- ⑤ Be careful when the unit is not packed or not installed.  
Pay attention to the sharp edges and fins of the heat exchanger.
- ⑥ After installation or repair, please confirm refrigerant is not leaking.  
If the refrigerant is not enough, the unit will not work properly.
- ⑦ The installation of the external unit must be flat and firm.  
Avoid abnormal vibration and noise.
- ⑧ Don't put your fingers into the fan and evaporator.  
High-speed running fan will result in serious injury.
- ⑨ This device is not designed for people who are physically or mentally weak (including children) and who does not have experience and knowledge of heating and cooling system. Unless it is used under the direction and supervision of a professional technician or has received training on the use of this unit. Children must use it under the supervision of an adult to ensure that they use the unit safely. If the power wire is damaged, it must be replaced by a professional technician to avoid danger.

## 1.5. Accessories

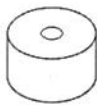
Name		Quantity
Installation & Instruction Manual		1
Operation Manual		1
Wire Controller		1
Temperature Sensor		4
Rubber Mat		4

## 2.OVERVIEW OF THE UNIT

### 2.1. Dimensions of the Unit

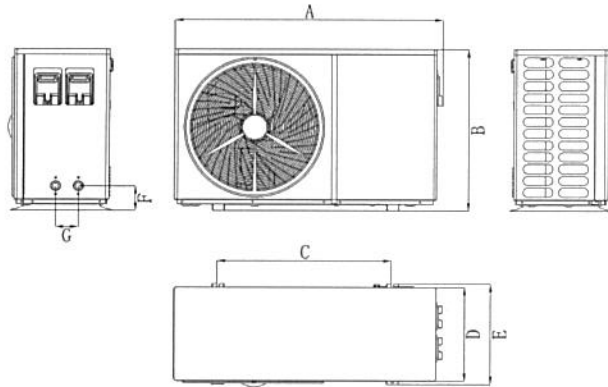

Dimension Unit: (mm)

Model	A	B	C	D	E	F	G
NE-F60HCR4INEM-SA	1180	715	768	414	440	109	99

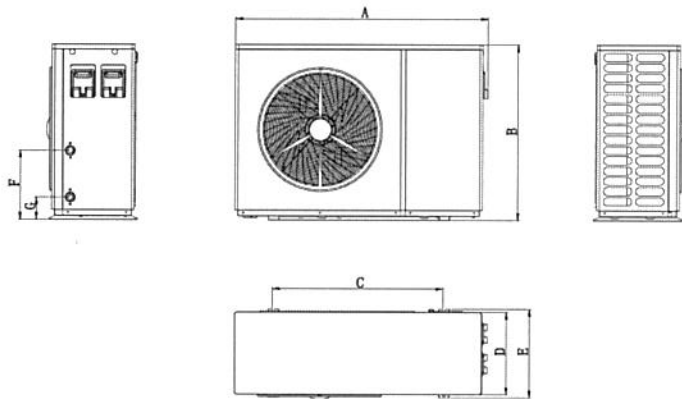

Dimension Unit: (mm)

Model	A	B	C	D	E	F	G
NE-F90HCR4INEM-SA	1263	875	848	410	440	345	112
NE-F90HCR4TINEM-SA							
NE-F130HCR4INEM-SA							
NE-F130HCR4TINEM-SA							

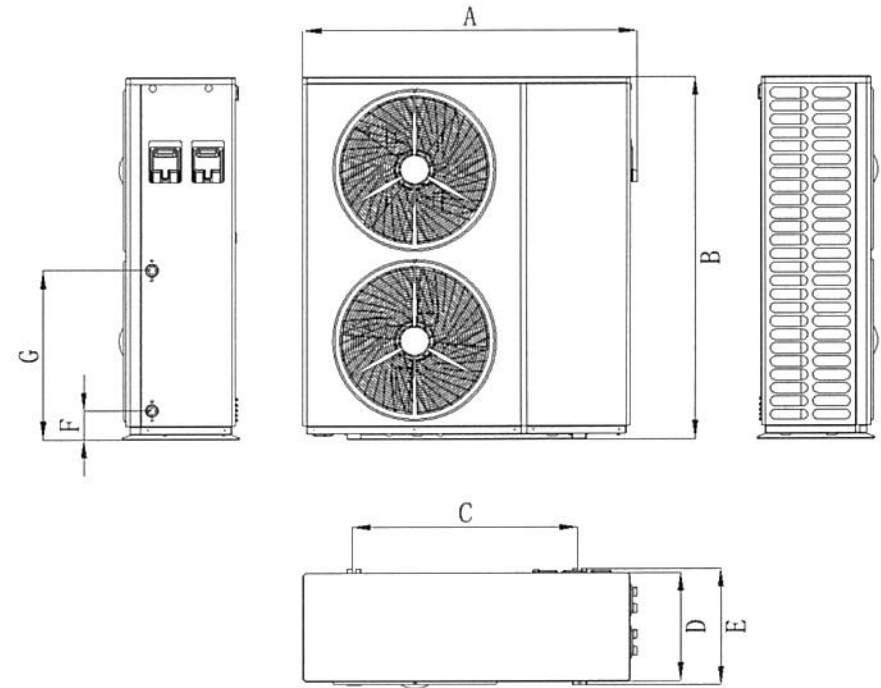

Dimension Unit: (mm)

Model	A	B	C	D	E	F	G
NE-F160HCR4INEM-SA	1263	1375	848	410	440	110	645
NE-F160HCR4TINEM-SA							
NE-F185HCR4TINEM-SA							
NE-F200HCR4TINEM-SA							
NE-F230HCR4TINEM-SA							
NE-F260HCR4TINEM-SA							



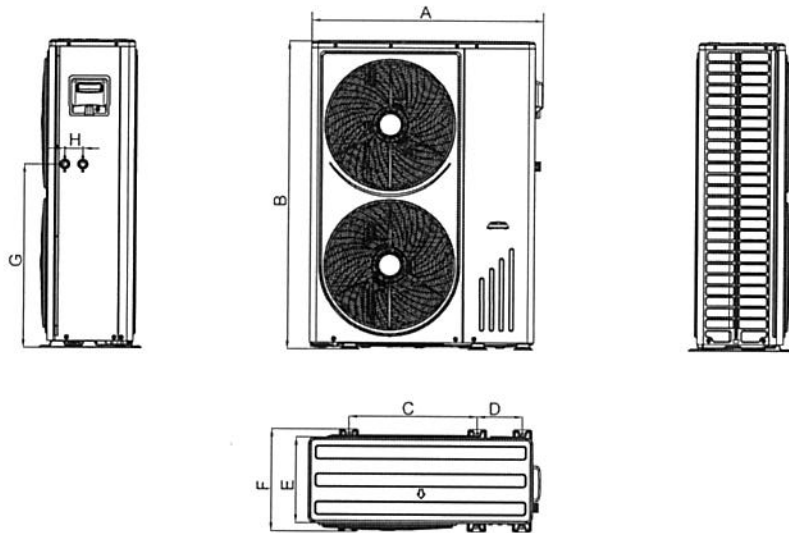

Model	A	B	C	D	E	F	G	H
NE-F300HCR4TINEM-SA	1172	1555	648	230	430	515	927	91
NE-F320HCR4TINEM-SA								

## 2.2. Main Parts of the Unit

NE-F60HCR4INEM-SA

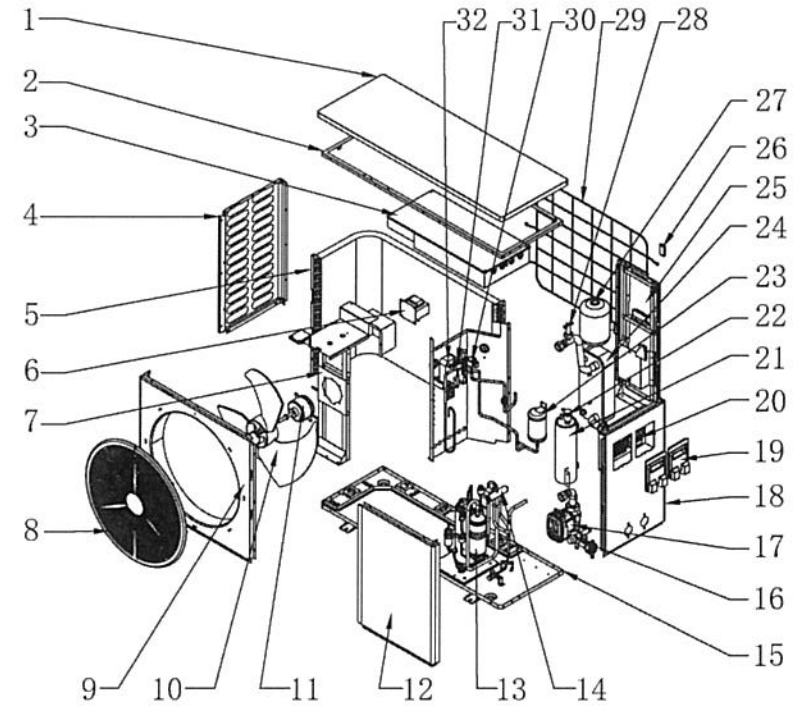

1	Top Cover	12	Front Service Plate	23	Liquid Reservoir
2	Fixed Frame	13	Compressor	24	Plate Heat Exchanger
3	Electrical Box	14	Four-way Valve Assembly	25	Back Service Plate
4	Left Plate	15	Chassis	26	Ambient Temp. Sensor
5	Finned Heat Exchanger	16	Pressure Relief Valve	27	Expansion Tank
6	Reactor	17	Water Pump	28	Water Flow Switch
7	Motor Support	18	Right Plate	29	Back Net
8	Mesh Cover	19	Handle	30	EEV
9	Air Guide Plate	20	Junction Box	31	EEV of EVI
10	Fan Blade	21	Electric Heater	32	Plate Heat Exchanger of
11	Fan Motor	22	Exhaust Valve		

NE-F90HCR4INEM-SA, NE-F90HCR4TINEM-SA  
NE-F130HCR4INEM-SA, NE-F130HCR4TINEM-SA

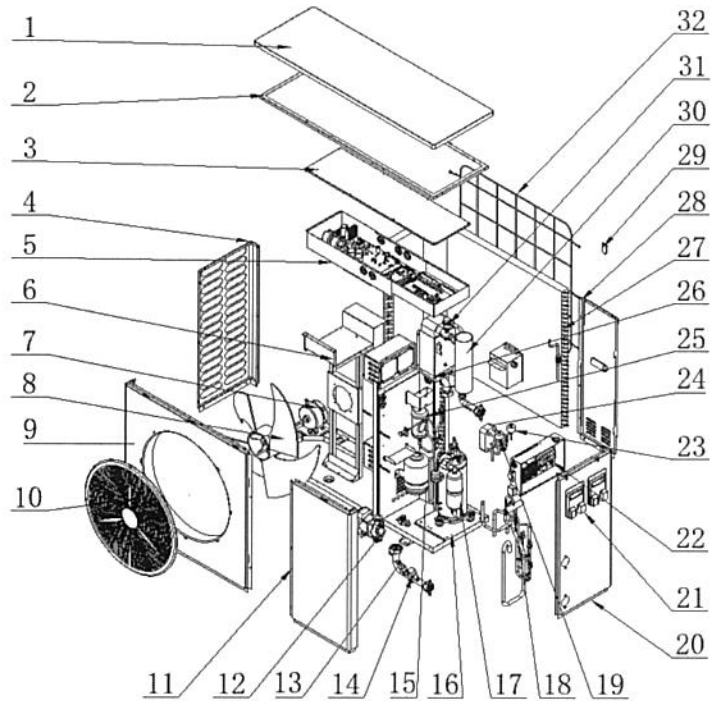

1	Top Cover	12	Water Pump	23	EEV
2	Fixed Frame	13	Water Flow Switch	24	Plate Heat Exchanger of
3	Electrical Box Cover	14	Pressure Relief Valve	25	Liquid Reservoir
4	Left Plate	15	Expansion Tank	26	Plate Heat Exchanger
5	Electrical Box	16	Chassis	27	Finned Heat Exchanger
6	Motor Support	17	Compressor	28	Back Service Plate
7	Fan Motor	18	Four-way Valve Assembly	29	Ambient Temp. Sensor
8	Fan Blade	19	EEV of EVI	30	Electric Heater
9	Air Guide Plate	20	Right Plate	31	Exhaust Valve
10	Mesh Cover	21	Handle	32	Back Net
11	Front Service Plate	22	Junction Box		

NE-F160HCR4INEM-SA, NE-F160HCR4TINEM-SA, NE-F185HCR4TINEM-SA  
NE-F200HCR4TINEM-SA, NE-F230HCR4TINEM-SA, NE-F260HCR4TINEM-SA

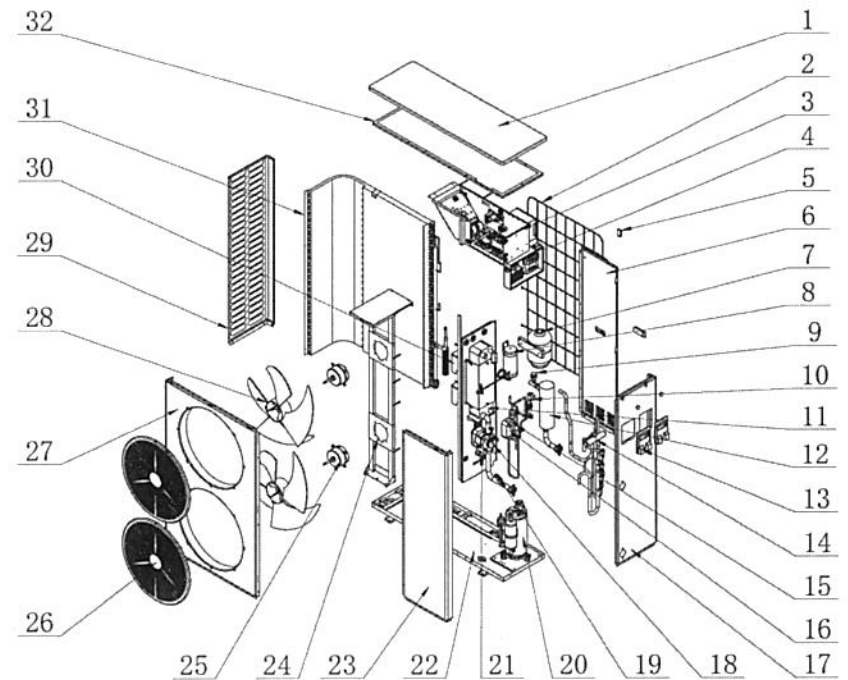

1	Top Cover	12	Electric Heater	23	Front Service Plate
2	Back Net	13	Handle	24	Motor Support
3	Electrical Box	14	Four-way Valve	25	Fan Motor
4	Junction Box	15	EEV of EVI	26	Mesh Cover
5	Ambient Temp. Sensor	16	Plate Heat Exchanger of	27	Air Guide Plate
6	Back Service Plate	17	Right Plate	28	Fan Blade
7	Expansion Tank	18	Water Pump	29	Left Plate
8	Liquid Reservoir	19	Water Flow Switch	30	Reactor
9	Exhaust Valve	20	Compressor	31	Finned Heat Exchanger
10	EEV	21	Pressure Relief Valve	32	Fixed Frame
11	Plate Heat Exchanger	22	Chassis		

NE-F300HCR4TINEM-SA, NE-F320HCR4TINEM-SA

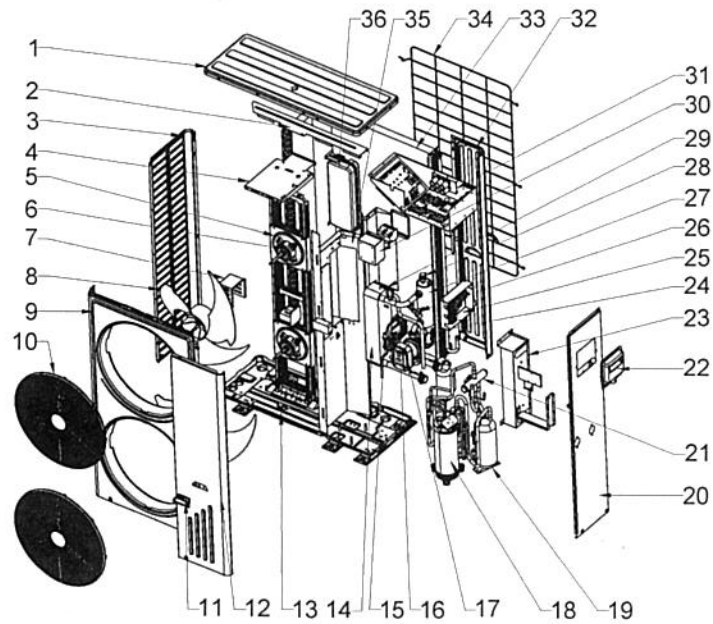

1	Top Cover	12	Front Service Plate	23	Plate Heat Exchanger
2	Fixed Frame	13	Chassis	24	EEV
3	Electrical Box Cover	14	Plate Heat Exchanger	25	Junction Box
4	Motor Support Fixing Plate	15	EEV of EVI	26	Pressure Relief Valve
5	Motor Support	16	Plate Heat Exchanger of	27	Electric Heater
6	Fan Motor	17	Water Pump	28	Exhaust Valve
7	Reactor Fixing Plate	18	Compressor	29	Water Flow Switch
8	Fan Blade	19	Gas-liquid Separator	30	Explosion-proof Box
9	Air Guide Plate	20	Right Plate	31	Electrical Box
10	Mesh Cover	21	Four-way Valve Assembly	32	Back Service Plate
11	Handle	22	Handle	33	Finned Heat Exchanger
34	Back Net	35	Middle Plate	36	Expansion Tank

Main Parts of the Unit Electrical Box  
NE-F60HCR4INEM-SA

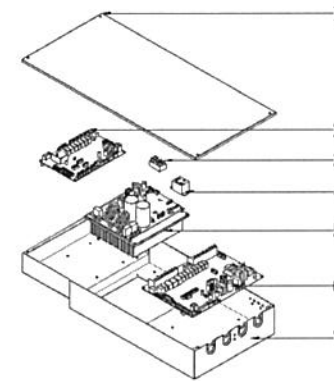

1	Electrical Box Cover
2	External Main Board
3	Terminal Block
4	Relay
5	Driver Board
6	Internal Main Board
7	Electrical Box

NE-F90HCR4INEM-SA, NE-F130HCR4INEM-SA

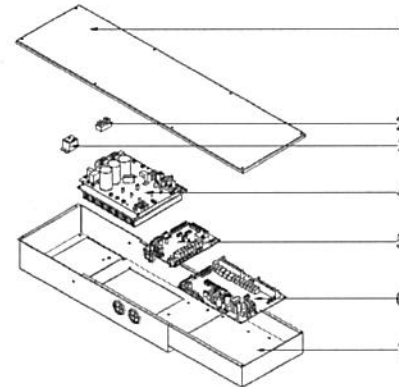

1	Electrical Box Cover
2	Terminal Block
3	Relay
4	Driver Board
5	External Main Board
6	Internal Main Board
7	Electrical Box



NE-F90HCR4TINEM-SA, NE-F130HCR4TINEM-SA

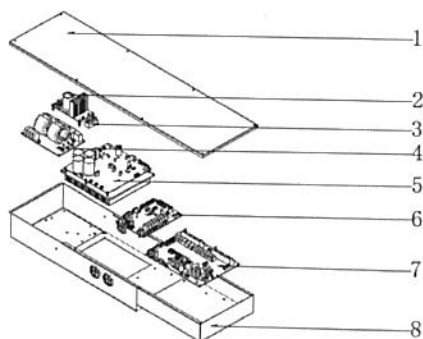

1	Electrical Box Cover
2	Fan Board
3	Terminal Block
4	Filter Board
5	Driver Board
6	External Main Board
7	Internal Main Board
8	Electrical Box

NE-F160HCR4INEM-SA, NE-F160HCR4TINEM-SA, NE-F185HCR4TINEM-SA  
NE-F200HCR4TINEM-SA, NE-F230HCR4TINEM-SA, NE-F260HCR4TINEM-SA

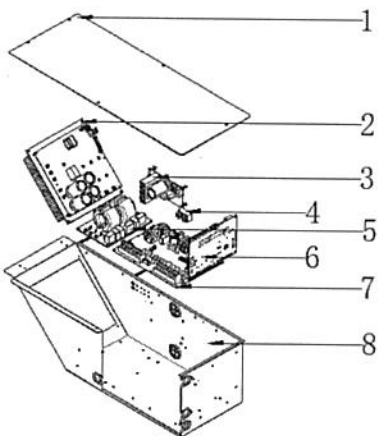

1	Electrical Box Cover
2	Driver Board
3	Fan Board
4	Terminal Block
5	Filter Board
6	External Main Board
7	Internal Main Board
8	Electrical Box

### 2.3. Parameter of the Unit

Model: NE-F	60HCR4INEM-SA
Power Supply	220-240V~/50Hz
Refrigerant Type	R32
[Space Heating] Ambient Temp. (DB/WB): 7°C/6°C, Water Temp. (Inlet/Outlet): 30°C/35°C.	
Max. Heating Capacity (kW)	1.73~6.06
Power Input (kW)	0.28~1.31
COP	6.18~4.63
[Space Heating] Ambient Temp. (DB/WB): 7°C/6°C, Water Temp. (Inlet/Outlet): 50°C/55°C.	
Max. Heating Capacity (kW)	1.12~5.29
Power Input (kW)	0.26~2.03
COP	4.31~2.61
[Space Cooling] Ambient Temp. (DB/WB): 35°C / -, Water Temp. (Inlet/Outlet): 12°C/7°C.	
Max. Cooling Capacity (kW)	0.97~4.86
Power Input (kW)	0.21~1.76
EER	4.62~2.76
[Hot Water] Ambient Temp. (DB/WB): 20°C/15°C, Water Temp. from 15°C to 55°C.	
Max. Heating Capacity (kW)	7.32
Power Input (kW)	1.73
COP	4.22
Electric Heater Rated Input (kW)	3
Max. Power Input (kW)	5.1(2.1+3)
Max. Running Current (A)	23.2(9.5+13.7)
Compressor Brand	Panasonic
Circulating Pump	Built-in
Water Side Heat Exchanger	Plate Heat Exchanger
Air Side Heat Exchanger	Finned Heat Exchanger
Expansion Tank (L)	2
Display	4-inch Colored Touch Screen
Rated Water Flow (m³/h)	1
Water Pressure Drop (kPa)	17
Water Pipe Connection (inch)	G1 1/4"
Sound Pressure Level dB(A) at 1m	46
Sound Power Level dB(A) at 1m	60
Operation Range (°C)	-25~43
Max. Outlet Water Temp. (°C)	60
Water Proof Class	IPX4
Electricity Shock Proof	I
Net Dimensions (L×W×H) (mm)	1180×440×715
Net Weight (kg)	85

Model: NE-F	90HCR4INEM-SA	130HCR4INEM-SA	160HCR4INEM-SA
Power Supply	220-240V~/50Hz		
Refrigerant Type	R32		
[Space Heating] Ambient Temp. (DB/WB): 7°C/6°C, Water Temp. (Inlet/Outlet): 30°C/35°C.			
Max. Heating Capacity (kW)	4.52~9.40	4.52~12.60	4.81~15.88
Power Input (kW)	0.89~2.03	0.89~2.74	0.81~3.91
COP	5.08~4.62	5.08~4.60	5.94~4.06
[Space Heating] Ambient Temp. (DB/WB): 7°C/6°C, Water Temp. (Inlet/Outlet): 50°C/55°C.			
Max. Heating Capacity (kW)	3.69~9.30	3.73~12.23	3.90~15.99
Power Input (kW)	1.50~3.31	1.59~4.31	1.03~5.92
COP	2.46~2.81	2.35~2.84	3.79~2.70
[Space Cooling] Ambient Temp. (DB/WB): 35°C / -, Water Temp. (Inlet/Outlet): 12°C/7°C.			
Max. Cooling Capacity (kW)	2.80~7.60	3.25~9.76	2.63~13.66
Power Input (kW)	1.10~2.22	0.87~3.74	0.59~4.81
EER	2.55~3.42	3.74~2.61	4.46~2.84
[Hot Water] Ambient Temp. (DB/WB): 20°C/15°C, Water Temp. from 15°C to 55°C.			
Max. Heating Capacity (kW)	11.04	13.50	16.81
Power Input (kW)	2.43	3.06	3.94
COP	4.54	4.41	4.27
Electric Heater Rated Input (kW)	3		
Max. Power Input (kW)	6.8(3.8+3)	7.7(4.7+3)	9.6(6.6+3)
Max. Running Current (A)	31(17.3+13.7)	35.1(21.4+13.7)	42.4(28.7+13.7)
Compressor Brand	Mitsubishi		Mitsubishi
Circulating Pump	Built-in		
Water Side Heat Exchanger	Plate Heat Exchanger		
Air Side Heat Exchanger	Finned Heat Exchanger		
Expansion Tank (L)	2	5	
Display	4-inch Colored Touch Screen		
Rated Water Flow (m³/h)	1.6	2.1	2.7
Water Pressure Drop (kPa)	20	22	24
Water Pipe Connection (inch)	G1 1/4"		
Sound Pressure Level dB(A) at 1m	55	55	53
Sound Power Level dB(A) at 1m	69	68~69	67~68
Operation Range (°C)	-25~43		
Max. Outlet Water Temp. (°C)	60		
Water Proof Class	IPX4		
Electricity Shock Proof	I		
Net Dimensions (L×W×H) mm	1263×440×875		1263×440×1375
Net Weight (kg)	107	111	153

Model: NE-F	90HCR4TINEM-SA	130HCR4TINEM-SA	160HCR4TINEM-SA	185HCR4TINEM-SA
Power Supply	380V-415V/3N~/50Hz		380V-415V/3N~/50Hz	
Refrigerant Type	R32			
[Space Heating] Ambient Temp. (DB/WB): 7°C/6°C, Water Temp. (Inlet/Outlet): 30°C/35°C.				
Max. Heating Capacity (kW)	4.52~9.40	4.52~12.60	4.81~15.88	6.15~18.57
Power Input (kW)	0.89~2.03	0.89~2.74	0.81~3.91	1.03~4.38
COP	5.08~4.62	5.08~4.60	5.94~4.06	5.97~4.24
[Space Heating] Ambient Temp. (DB/WB): 7°C/6°C, Water Temp. (Inlet/Outlet): 50°C/55°C.				
Max. Heating Capacity (kW)	3.69~9.30	3.73~12.23	3.90~15.99	3.44~17.13
Power Input (kW)	1.50~3.31	1.59~4.31	1.03~5.92	0.78~6.18
COP	2.46~2.81	2.35~2.84	3.79~2.70	4.41~2.77
[Space Cooling] Ambient Temp. (DB/WB): 35°C / -, Water Temp. (Inlet/Outlet): 12°C/7°C.				
Max. Cooling Capacity (kW)	2.80~7.60	3.25~9.76	2.63~13.66	3.12~15.25
Power Input (kW)	1.10~2.22	0.87~3.74	0.59~4.81	0.71~5.01
EER	2.55~3.42	3.74~2.61	4.46~2.84	4.39~3.04
[Hot Water] Ambient Temp. (DB/WB): 20°C/15°C, Water Temp. from 15°C to 55°C.				
Max. Heating Capacity (kW)	11.04	13.5	16.81	22.29
Power Input (kW)	2.43	3.06	3.94	5.16
COP	4.54	4.41	4.27	4.32
Electric Heater Rated Input (kW)	3/6/9(optional)		3/6/9(optional)	
Max. Power Input (kW)	6.8(3.8+3)	7.7(4.7+3)	9.6(6.6+3)	9.6(6.6+3)
	9.8(3.8+6)	10.7(4.7+6)	12.6(6.6+6)	12.6(6.6+6)
	12.8(3.8+9)	13.7(4.7+9)	15.6(6.6+9)	15.6(6.6+9)
Max. Running Current (A)	19.2(5.5+13.7)	21.5(7.8+13.7)	25.2(11.5+13.7)	25.2(11.5+13.7)
	14.6(5.5+9.1)	16.9(7.8+9.1)	20.6(11.5+9.1)	20.6(11.5+9.1)
	19.2(5.5+13.7)	21.5(7.8+13.7)	25.2(11.5+13.7)	25.2(11.5+13.7)
Compressor Brand	Mitsubishi		Mitsubishi	
Circulating Pump	Built-in			
Water Side Heat Exchanger	Plate Heat Exchanger			
Air Side Heat Exchanger	Finned Heat Exchanger			
Expansion Tank (L)	2	5		
Display	4-inch Colored Touch Screen			
Rated Water Flow (m³/h)	1.6	2.1	2.7	3.1
Water Pressure Drop (kPa)	20	22	24	26
Water Pipe Connection (inch)	G1 1/4"			
Sound Pressure Level dB(A) at	51	53	53	55
Sound Power Level dB(A) at	65~66	66~67	67~68	69~71
Operation Range (°C)	-25~43			
Max. Outlet Water Temp.	60			
Water Proof Class	IPX4			
Electricity Shock Proof	I			
Net Dimensions (L×W×H)	1263×440×875		1263×440×1375	
Net Weight (kg)	121	125	163	166



Model: NE-F	200HCR4TINEM-SA	230HCR4TINEM-SA	260HCR4TINEM-SA
Power Supply	380V-415V/3N ~ / 50Hz		
Refrigerant Type	R32		
[Space Heating] Ambient Temp. (DB/WB): 7°C/6°C, Water Temp. (Inlet/Outlet): 30°C/35°C.			
Max. Heating Capacity (kW)	6.36~20.49	8.43~23.04	8.54~26.08
Power Input (kW)	1.08~4.89	1.41~5.15	1.46~6.26
COP	5.89~4.19	5.98~4.47	5.85~4.17
[Space Heating] Ambient Temp. (DB/WB): 7°C/6°C, Water Temp. (Inlet/Outlet): 50°C/55°C.			
Max. Heating Capacity (kW)	3.41~18.8	4.41~22.6	4.67~25.9
Power Input (kW)	0.89~7.13	1.01~8.24	1.04~9.62
COP	3.83~2.64	4.37~2.74	4.49~2.69
[Space Cooling] Ambient Temp. (DB/WB): 35°C / -, Water Temp. (Inlet/Outlet): 12°C/7°C.			
Max. Cooling Capacity (kW)	3.31~17.4	3.80~19.38	4.37~21.4
Power Input (kW)	0.76~6.14	0.88~6.31	1.02~7.32
EER	4.36~2.83	4.31~3.07	4.28~2.92
[Hot Water] Ambient Temp. (DB/WB): 20°C/15°C, Water Temp. from 15°C to 55°C.			
Max. Heating Capacity (kW)	23.97	23.86	26.98
Power Input (kW)	5.65	5.45	6.47
COP	4.24	4.38	4.17
Electric Heater Rated Input (kW)	3/6/9(optional)		
Max. Power Input (kW)	10.5(7.5+3)	13(10+3)	14.5(11.5+3)
	13.5(7.5+6)	16(10+6)	17.5(11.5+6)
	16.5(7.5+9)	19(10+9)	20.5(11.5+9)
Max. Running Current (A)	26.4(12.7+13.7)	30.6(16.9+13.7)	33.2(19.5+13.7)
	21.8(12.7+9.1)	26(16.9+9.1)	28.6(19.5+9.1)
	26.4(12.7+13.7)	30.6(16.9+13.7)	33.2(19.5+13.7)
Compressor Brand	Mitsubishi		
Circulating Pump	Built-in		
Water Side Heat Exchanger	Plate Heat Exchanger		
Air Side Heat Exchanger	Finned Heat Exchanger		
Expansion Tank (L)	5		
Display	4-inch Colored Touch Screen		
Rated Water Flow (m³/h)	3.4	4	4.4
Water Pressure Drop (kPa)	28	51	51
Water Pipe Connection (inch)	G1 1/4"	G1 1/4"	G1 1/4"
Sound Pressure Level dB(A) at 1m	56	57	57
Sound Power Level dB(A) at 1m	71	71~73	71~72
Operation Range (°C)	-25~43		
Max. Outlet Water Temp. (°C)	60		
Water Proof Class	IPX4		
Electricity Shock Proof	I		
Net Dimensions (L×W×H) (mm)	1263×440×1375		
Net Weight (kg)	168	171	173

Model: NE-F	300HCR4TINEM-SA	320HCR4ITNEM-SA
Power Supply	380V-415V/3N ~ / 50Hz	
Refrigerant Type	R32	
[Space Heating] Ambient Temp. (DB/WB): 7°C/6°C, Water Temp. (Inlet/Outlet): 30°C/35°C.		
Max. Heating Capacity (kW)	11.54~29.82	12.86~31.74
Power Input (kW)	1.90~6.95	2.18~7.58
COP	6.07~4.29	5.90~4.19
[Space Heating] Ambient Temp. (DB/WB): 7°C/6°C, Water Temp. (Inlet/Outlet): 50°C/55°C.		
Max. Heating Capacity (kW)	7.81~28.93	8.73~30.91
Power Input (kW)	1.77~11.17	1.99~12.22
COP	4.41~2.59	4.39~2.53
[Space Cooling] Ambient Temp. (DB/WB): 35°C / -, Water Temp. (Inlet/Outlet): 12°C/7°C.		
Max. Cooling Capacity (kW)	7.64~25.85	8.91~28.14
Power Input (kW)	1.77~9.68	2.08~10.86
EER	4.32~2.67	4.28~2.59
[Hot Water] Ambient Temp. (DB/WB): 20°C/15°C, Water Temp. from 15°C to 55°C.		
Max. Heating Capacity (kW)	33.75	35.69
Power Input (kW)	7.78	8.34
COP	4.34	4.28
Electric Heater Rated Input (kW)	3/6/9(optional)	
Max. Power Input (kW)	15.2(12.2+3)	15.8(12.8+3)
	18.2(12.2+6)	18.8(12.8+6)
	21.2(12.2+9)	21.8(12.8+9)
Max. Running Current (A)	34.4(20.7+13.7)	35.5(21.8+13.7)
	29.8(20.7+9.1)	30.9(21.8+9.1)
	34.4(20.7+13.7)	35.5(21.8+13.7)
Compressor Brand	Mitsubishi	
Circulating Pump	Built-in	
Water Side Heat Exchanger	Plate Heat Exchanger	
Air Side Heat Exchanger	Finned Heat Exchanger	
Expansion Tank (L)	10	
Display	4-inch Colored Touch Screen	
Rated Water Flow (m³/h)	5.2	5.5
Water Pressure Drop (kPa)	90	100
Water Pipe Connection (inch)	G1 1/4"	
Sound Pressure Level dB(A) at 1m	60	60
Sound Power Level dB(A) at 1m	63~76	63~76
Operation Range (°C)	-25~43	
Max. Outlet Water Temp. (°C)	60	
Water Proof Class	IPX4	
Electricity Shock Proof	I	
Net Dimensions (L×W×H) (mm)	1172×430×1555	
Net Weight (kg)	200	200



### 3.INSTALLATION AND CONNECTION

#### ⚠ WARNING

The heat pump must be installed by a professional team. The users are not qualified to install it by themselves, otherwise, the heat pump might be damaged and risky for users' safety.

This section is provided for information purposes only and must be checked and adapted if necessary according to the actual installation conditions.

#### 3.1. Transportation

1. When storing or moving the heat pump, the heat pump should be in the upright position.

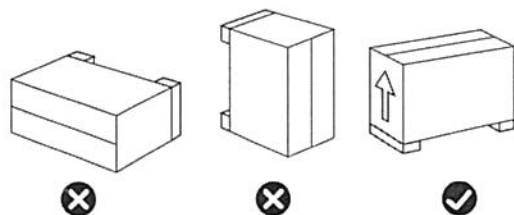

2. When moving the heat pump, do not lift the water union since the titanium heat exchanger inside the heat pump will be damaged.

#### 3.2. Installation Instruction

##### 3.2.1. Pre-requirements

**Equipment necessary for the installation of your heat pump:**

- ① Power supply cable suitable for the unit's power requirements.
- ② A By-Pass kit and an assembly of PVC tubing suitable for your installation as well as stripper, PVC adhesive, and sandpaper.
- ③ A set of wall plugs and expansion screws suitable to attach the unit to your support.
- ④ We recommend that you connect the unit to your installation by means of flexible PVC pipes in order to reduce the transmission of vibrations.
- ⑤ Suitable fastening studs may be used to raise the unit.

##### 3.2.2. Location and Space

Please comply with the following rules concerning the choice of heat pump location.

- ① The unit's future location must be easily accessible for convenient operation and maintenance.
- ② It must be installed on the ground, fixed ideally on a level concrete floor. Ensure that the floor is sufficiently stable and can support the weight of the unit.
- ③ A water drainage device must be provided close to the unit in order to protect the area

where it is installed.

- ④ If necessary, the unit may be raised by using suitable mounting pads designed to support its weight.
- ⑤ Check that the unit is properly ventilated, that the air outlet is not facing the windows of neighbouring buildings and that the exhaust air cannot return. In addition, provide sufficient space around the unit for servicing and maintenance operations.
- ⑥ The unit must not be installed in an area exposed to oil, flammable gases, corrosive products, sulphur compounds, or close to high-frequency equipment.
- ⑦ To prevent mud splashes, do not install the unit near a road or track.
- ⑧ To avoid causing a nuisance to neighbors, make sure the unit is installed so that it is positioned towards the area that is least sensitive to noise.
- ⑨ Keep the unit as much as possible out of the reach of children.

#### Installation space:

The unit shall be installed in a place with air circulation, no heat radiation or other heat sources, and the allowable minimum distance between the unit and the surrounding walls or other shelters is: the distance between the air inlet surface and the air inlet surface is more than 300 mm, the distance between every 2 units is more than 600 mm, as shown in the figure:

Unit: mm

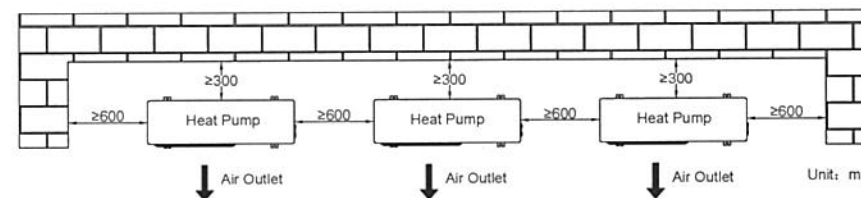
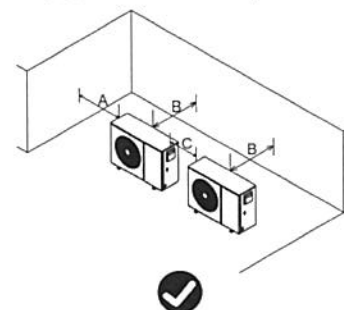
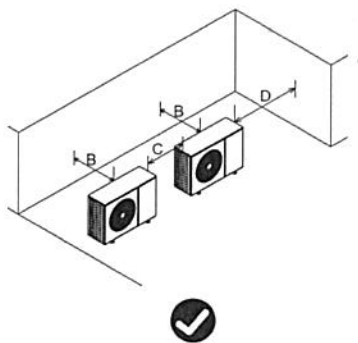

Diagram of the unit installation:

1. It is recommended that the unit be installed in an open position with no obstacle blocking the air outlet of the unit, as shown in the diagram.



	Unit	Min. Distance
A	mm	600
B	mm	300
C	mm	600



	Unit	Min. Distance
B	mm	300
C	mm	600
D	mm	600

2. It is not recommended to install the unit according to the following installation method.

① Do not make the air outlet of the unit blow against the air inlet of another unit and do not make the air outlet of the unit blow against the air outlet of another unit.

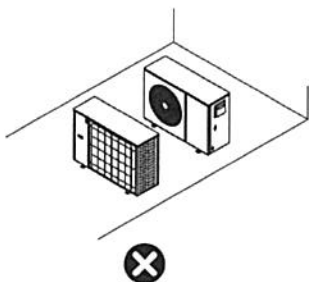
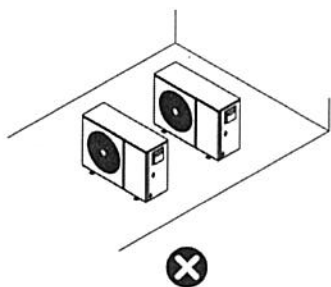

② Don't make the air inlet of the unit opposite to each other and don't make the air inlet of the unit blocked by the wall.

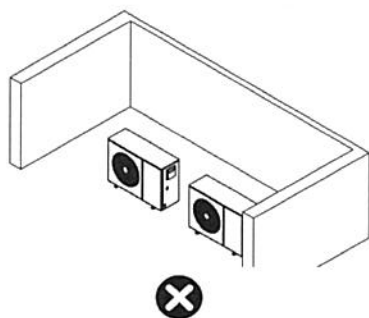
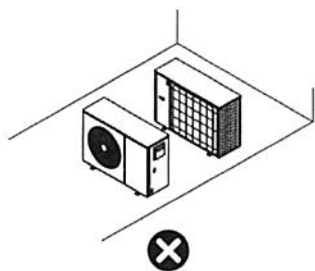

③ Do not install the unit vertically up and down. The condensate of the unit is discharged from the chassis. If the condensate of the unit drips onto the unit below, it will easily cause the unit below to freeze.

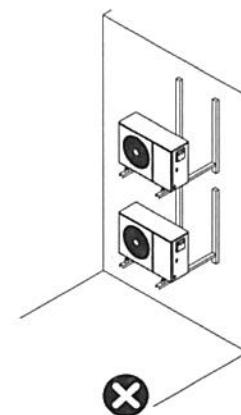

In snowy areas, anti-snow facilities shall be installed. In order not to be affected by snow, an elevated platform is adopted, and an anti-snow shed is installed at the air inlet and air outlet.

Snow Protection Shed Diagram

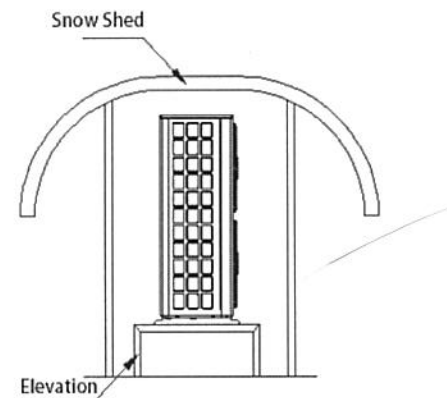

### 3.2.3. Installation Layout

Notice:

- ① Flexible connection between the unit and circulating water pipe can prevent vibration from unit to water pipe.
- ② The gate valve must be installed at the inlet/outlet of the unit. When the pressure test is completed after the installation of the end of the water system, the gate valve shall be closed for the pressure test.
- ③ Open after discharge.
- ④ "Y" filter (60 mesh) must be installed at the inlet pipe of the main engine to effectively prevent impurities from damaging the unit.
- ⑤ Clean water quality regularly and use.
- ⑥ Installation of the relief valve, bypass valve, and other valve parts must be in the direction of the arrow of the valve body.
- ⑦ After installation, water injection is required to detect leakage, confirm no leakage, and clean the filter.

The installation diagram is shown in the following figure:

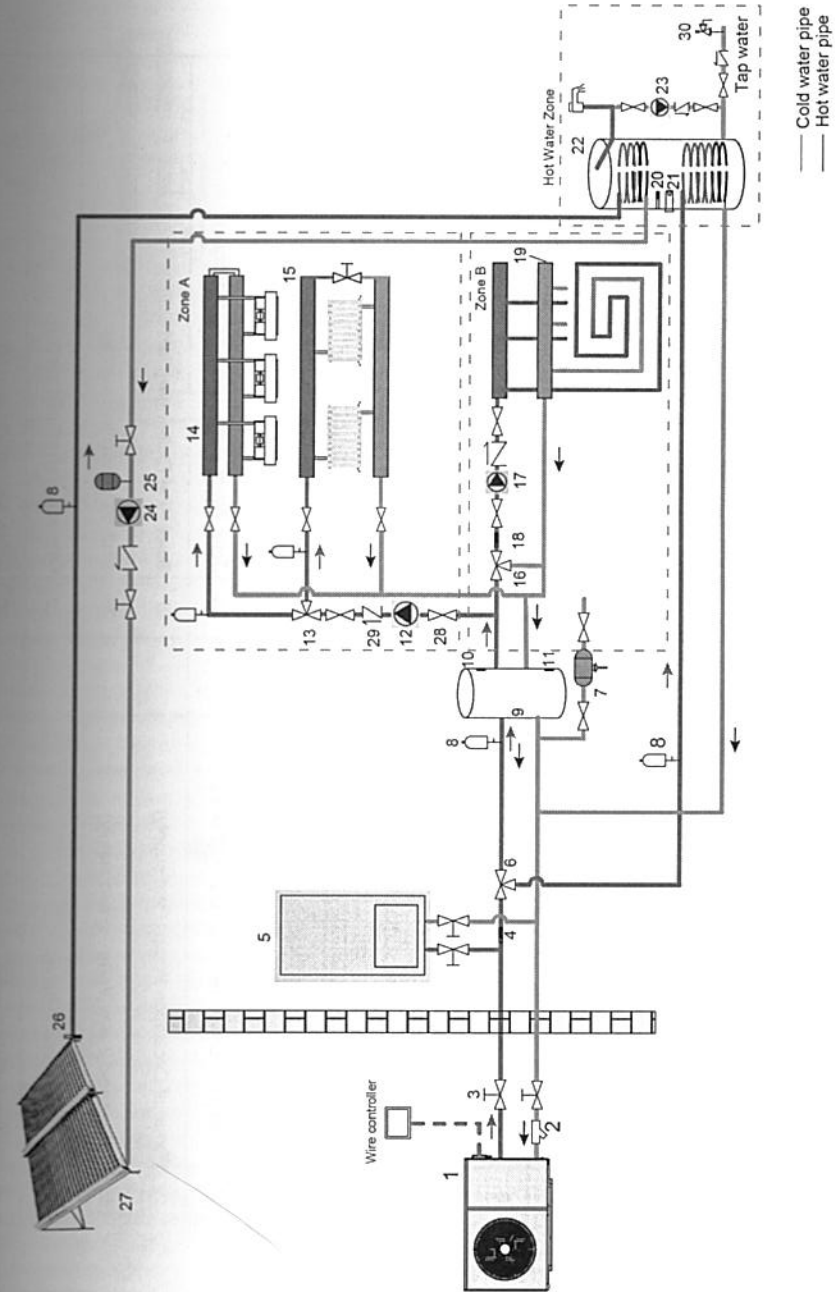

Heating&Cooling+Hot water Installation Instructions Schematic



NO.	Meaning	NO.	Meaning
1	Outdoor Unit	16	3#Solenoid 3-way Valve (Field supply)
2	Y-type Filter (Field supply)	17	Mixing Water Pump (Field supply)
3	Manual Ball Valve (Field supply)	18	Floor Heating Inlet Water Temp. Sensor (Accessories)
4	Total System Outlet Water Temp. Sensor(Accessories)	19	Floor Heating Loop (Field supply)
5	Auxiliary Heat Source (Field supply)	20	Hot Water Tank Temp. Sensor (Accessories)
6	1#Solenoid 3-way Valve (Field supply)	21	Hot Water Tank Electric Heater (Optional)
7	Water Refill Valve (Field supply)	22	Hot Water Tank (Field supply)
8	Automatic Exhaust Valve (Field supply)	23	Lower Return Water Pump (Field supply)
9	Buffer Tank (Field supply)	24	Solar Pump (Field supply)
10	Buffer Tank Upper Temp. Sensor (Optional)	25	Expansion Tank (Field supply)
11	Buffer Tank Lower Temp. Sensor (Optional)	26	Solar Water Temp. Sensor(Accessories)
12	External Circulation Pump (Field supply)	27	Solar Heat Exchanger(Field supply)
13	2#Solenoid 3-way Valve (Field supply)	28	Shut-off Valve(Field supply)
14	Fan Coils(Field supply)	29	One-way Valve(Field supply)
15	Radiator (Field supply)	30	Safety Valve(Field supply)

30

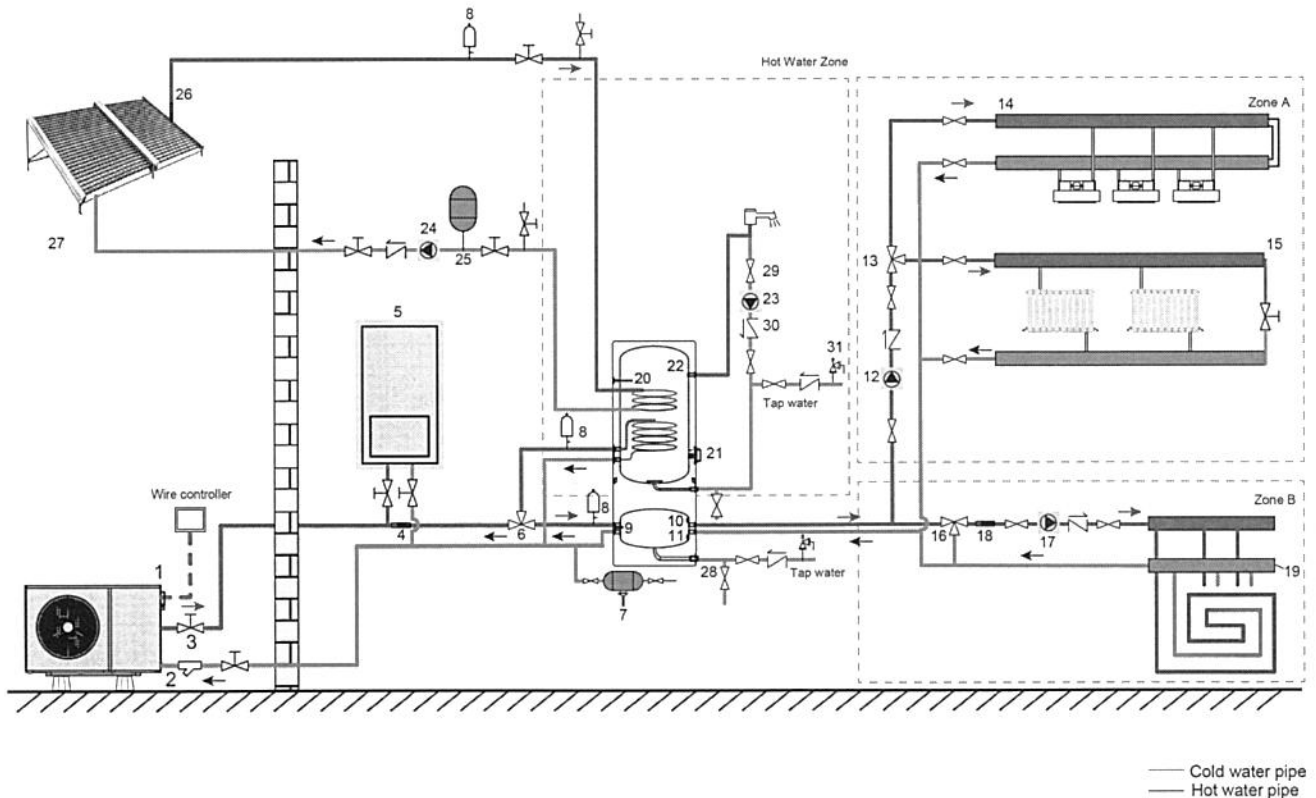

31

Heating&Cooling+Hot water Installation Instructions Schematic

NO.	Meaning	NO.	Meaning
1	Outdoor Unit	16	3#Solenoid 3-way Valve (Field supply)
2	Y-type Filter (Field supply)	17	Mixing Water Pump (Field supply)
3	Manual Ball Valve (Field supply)	18	Floor Heating Inlet Water Temp. Sensor (Accessories)
4	Total System Outlet Water Temp. Sensor(Accessories)	19	Floor Heating Loop (Field supply)
5	Auxiliary Heat Source (Field supply)	20	Hot Water Tank Temp. Sensor (Accessories)
6	1#Solenoid 3-way Valve (Field supply)	21	Hot Water Tank Electric Heater (Optional)
7	Water Refill Valve (Field supply)	22	Hot Water Tank (Field supply)
8	Automatic Exhaust Valve (Field supply)	23	Lower Return Water Pump (Field supply)
9	Buffer Tank (Field supply)	24	Solar Pump (Field supply)
10	Buffer Tank Upper Temp. Sensor (Optional)	25	Expansion Tank (Field supply)
11	Buffer Tank Lower Temp. Sensor (Optional)	26	Solar Water Temp. Sensor(Accessories)
12	External Circulation Pump (Field supply)	27	Solar Heat Exchanger(Field supply)
13	2#Solenoid 3-way Valve (Field supply)	28	Drain Valve(Field supply)
14	Fan Collis(Field supply)	29	Shut-off Valve(Field supply)
15	Radiator (Field supply)	30	One-way Valve(Field supply)
		31	Safety Valve(Field supply)

### 3.2.4. Electrical Installation

To function safely and maintain the integrity of your electrical system, the unit must be connected to a general electricity supply under the following regulations:

- ① Upstream, the general electricity supply must be protected by a 30mA differential switch.
- ② The heat pump must be connected to a suitable D-curve circuit breaker in accordance with current standards and regulations in the country where the system is installed.
- ③ The electricity supply cable must be adapted to match the unit's rated power and the length of wiring required by the installation. The cable must be suitable for outdoor use.
- ④ For a three-phase system, it is essential to connect the phases in the correct sequence. If the phases are inverted, the heat pump's compressor will not work.
- ⑤ In places open to the public, it is mandatory to install an emergency stop button close to the heat pump.

Model	Power Supply Wires		
	Electricity Supply	Cable Diameter	Specification
NE-F40HCR4INEM-SA	220-240V~/ 50Hz	3G 2.5mm <sup>2</sup>	AWG 12
NE-F60HCR4INEM-SA		3G 4mm <sup>2</sup>	AWG 10
NE-F90HCR4INEM-SA		3G 6mm <sup>2</sup>	AWG 8
NE-F130HCR4INEM-SA		3G 6mm <sup>2</sup>	AWG 8
NE-F160HCR4INEM-SA		3G 10mm <sup>2</sup>	AWG 6
NE-F90HCR4TINEM-SA	380V-415V/3N ~/ 50Hz	5G 4mm <sup>2</sup>	AWG 12
NE-F130HCR4TINEM-SA		5G 4mm <sup>2</sup>	AWG 12
NE-F160HCR4TINEM-SA		5G 4mm <sup>2</sup>	AWG 10
NE-F185HCR4TINEM-SA		5G 4mm <sup>2</sup>	AWG 10
NE-F200HCR4TINEM-SA		5G 4mm <sup>2</sup>	AWG 10
NE-F230HCR4TINEM-SA		5G 6mm <sup>2</sup>	AWG 8
NE-F260HCR4TINEM-SA		5G 6mm <sup>2</sup>	AWG 8
NE-F300HCR4TINEM-SA	380V-415V/3N ~/ 50Hz	5G 6mm <sup>2</sup>	AWG 8
NE-F320HCR4TINEM-SA		5G 6mm <sup>2</sup>	AWG 8

### 3.2.5. Electrical Connection

#### ⚠ WARNING

- Parts of the main switch or other disconnect switch that have a separate connection point on all branch lines must be incorporated into the prescribed wiring in accordance with relevant local laws and regulations. Turn off the power before making any connections. Only copper wire can be used. Never pinch the bundled wires, and make sure they don't touch pipes and sharp edges. Make sure that no external pressure is applied to the terminal connections. All field wiring and components must be installed by a licensed electrician and must comply with relevant local laws and regulations.
- Field wiring must be done in accordance with the wiring diagram supplied with the unit and the instructions given below.  
Be sure to use a dedicated power supply. Never use a power source shared by other devices.

- Be sure to build a foundation. Do not ground the device to a utility pipe, surge protector, or telephone ground. Incomplete grounding may result in electric shock.  
Be sure to install a ground fault circuit interrupter (30 mA). Failure to do so may result in electric shock.
- Be sure to install the required fuse or circuit breaker.

#### Precautions for installing wires

- Secure the wires so that they do not come into contact with the pipes (especially the high voltage side)
- Secure the wires with cable ties as shown so that they do not touch the pipe, especially the high voltage side.
- Make sure that no external pressure is applied to the terminal connectors.
- When installing a ground fault circuit interrupter, make sure it is compatible with the inverter (anti-high frequency electrical noise) to avoid opening the ground fault circuit interrupter unnecessarily.

When installing a ground fault circuit interrupter, make sure it is compatible with the inverter (anti-high frequency electrical noise) to avoid opening the ground fault circuit interrupter unnecessarily.

#### NOTE

- This unit is equipped with an inverter. Installing a phase leading capacitor not only reduces the power factor improvement effect, but also may cause abnormal heating of the capacitor due to high frequency waves. Never install a phase lead capacitor as it may cause an accident.

#### Wiring overview

#### NOTE

- Please use the H07RN-F power cord, except the thermistor cable and user interface cable, all other wires are connected to the high voltage end. The equipment must be grounded.
- All high voltage external loads, if metallic or grounded, must be grounded.
- All external load currents must be less than 0.2A. If a single load current is greater than 0.2A, the load must be controlled through an AC contactor.  
"AHS1, AHS2", "DFR1, DFR2" and "ERR1, ERR2" terminal ports only provide switching signals.
- The "DI2, G" and "SG, EVU, G" terminal ports receive switching signals.  
See the image below for the port location in the device.

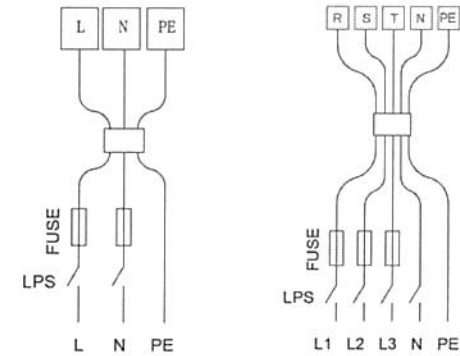

#### 1. Customer Installation Wiring Section

- ① Open the handle on the right side of the unit
- ② Wiring Section

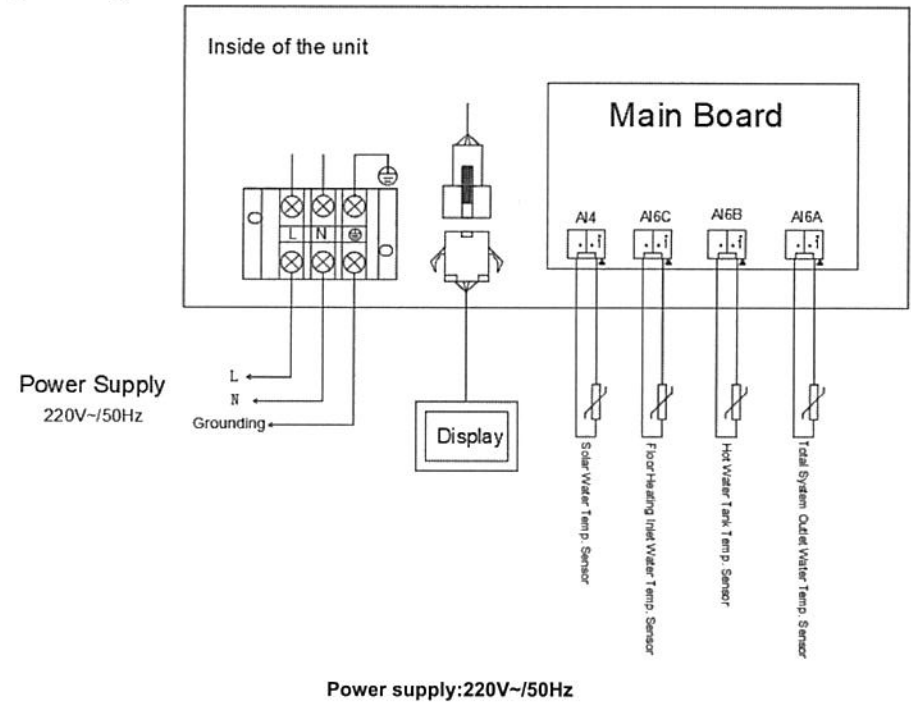



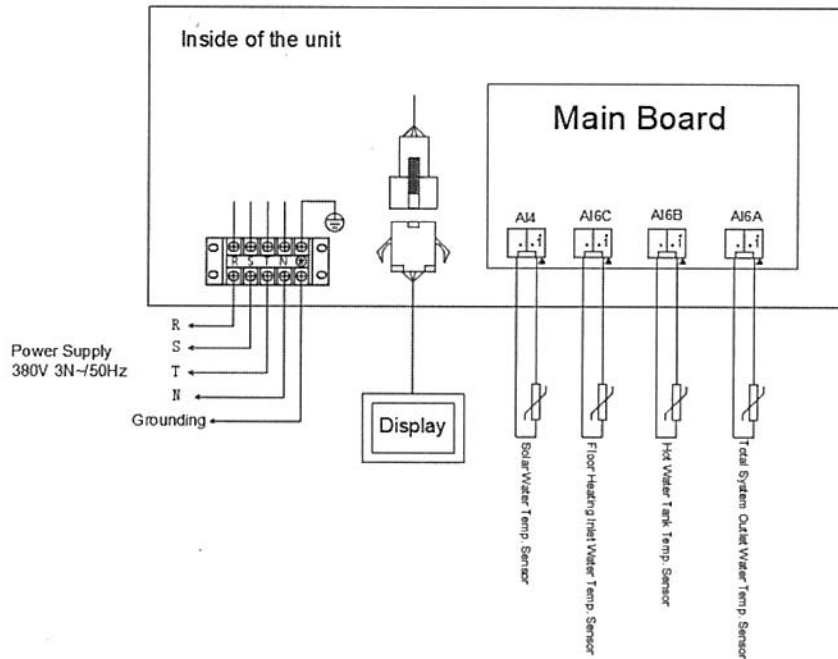

Power supply:380V 3N~50Hz

**NOTE**

- The ground fault circuit breaker must be a 30 mA (<0.1 s) high speed type circuit breaker. Please use a cable with the corresponding number of cores and specifications.
- The current rating is based on the allowable maximum operating temperature of the conductor (105°C/70°C) and the rated ambient temperature (40°C/25°C), and assumes that the single wire is freely separated in the air, and the wire diameter comparison table is as follows.

The maximum operating current of the unit (A)	Wire cross-sectional area (AWG)	The maximum operating current of the unit (A)	Wire cross-sectional area (AWG)
≤3.0	≥24	≤15	≥14
≤4.6	≥22	≤21	≥12
≤6.5	≥20	≤28	≥10
≤8.5	≥18	≤40	≥8
≤11	≥16	≤55	≥6

**Connection of other components**

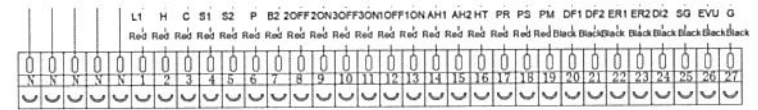

Print	Connect to	Print	Connect to
N	Null Line	14-15	External Heat Source
1-2	Thermostat (H Signal)	16-N	Anti-freeze Electric Heater Belts
1-3	Thermostat (C Signal)	17-N	Lower Return Pump
4-5	Solar Signal	18-N	Solar Pump
6-N	Outside Circulator Pump	19-N	Mixing Water Pump
7-N	Electric Heater for Water Tank	20-21	Defrost Indication
8-N	2# Three-Way Valve (Heating Direction)	22-23	Fault Indication
9-N	2# Three-Way Valve (Cooling Direction)	24-27	Linkage Switch
10-N	3# Three-Way Valve (Open Circulation)	25-27	Smart Grid (SG)
11-N	3# Three-Way Valve (Close Circulation)	26-27	Smart Grid (EVU)
12-N	1# Three-Way Valve (DHW Direction)		
13-N	1# Three-Way Valve (H&C Direction)		

**Function instructions:**

1. Output: control method

**Type 1:** Non-voltage dry connector.

**Type 2:** The port provides a signal of 220V voltage. If the load current is <0.2A, the load can be directly connected to the port.

If the load current ≥ 0.2A, you need to connect the AC contactor to the load.

**1) For Three-way Valve**

Please use the three-wire two-control three-way valve when installing the waterway. The wiring diagram of the three-way valve is shown in the figure below:

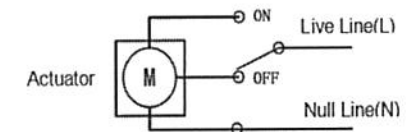

The wiring specifications of the three-way valve are shown in the figure below:

Voltage	220-240VAC
Maximum Current	0.2A
Wire Specifications	20AWG/0.75mm <sup>2</sup>
Control Method	Type 2

**1# Electromagnetic three-way valve wiring**

The electromagnetic three-way valve is used to switch the Heating & Cooling waterway and the hot water waterway.

During construction and installation, it is necessary to connect the three-way valve

control line to the corresponding point on the terminal block of the unit.

When the unit running Heating & Cooling mode, the 12# wiring point has 220V voltage output, and the 13# point has no output; when the unit is running hot water mode, the 13# point has 220V voltage output, and the 12# point has no output. When wiring, it is necessary to confirm each waterway interface of the electromagnetic three-way valve to ensure that the three-way valve is switched to the correct waterway when the unit is running.

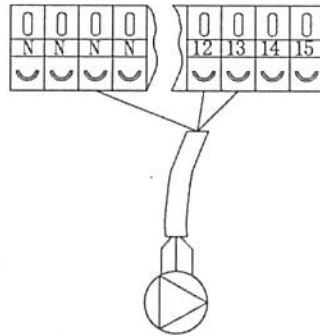

1#Electromagnetic 3-way valve

### 2# Electromagnetic three-way valve wiring

The 2# electromagnetic three-way valve is used to switch the Heating & Cooling water channels of the air conditioner. During construction and installation, the control line of the three-way valve needs to be connected to the corresponding point on the terminal block of the unit. When the air conditioner of the unit is heating, the 8# wiring point has 220V voltage output, and the 9# point has not output; when the unit is cooling, the 9# point has 220V voltage output, and the 8# point has no output. When wiring, it is necessary to confirm each waterway interface of the electromagnetic three-way valve to ensure that the

three-way valve is switched to the correct waterway when the unit is running.

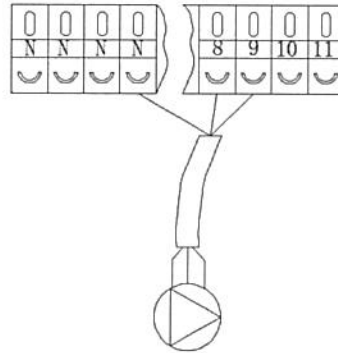

2#Electromagnetic 3-way valve

### 3# Electromagnetic three-way valve wiring

The 3# electromagnetic three-way valve is used to control whether the water in the balance water tank enters the floor heating waterway in area B.

When the floor heating water temperature is too high, the three-way valve switches direction. At this time, the floor heating water circuit circulates in the floor heating pipe, and the hot water in the balance tank does not enter the floor heating. The 11# point maintains 220V output, and the 10# point has no output; the local heating water temperature If it is too low, the hot water in the balance water tank will enter the floor heating in zone B after the three-way valve is reversed. At this time, the 10# point maintains 220V output, and the 11# point has no output.

When wiring, it is necessary to confirm each waterway interface of the electromagnetic three-way valve to ensure that the three-way valve is switched to the correct waterway when the unit is running.

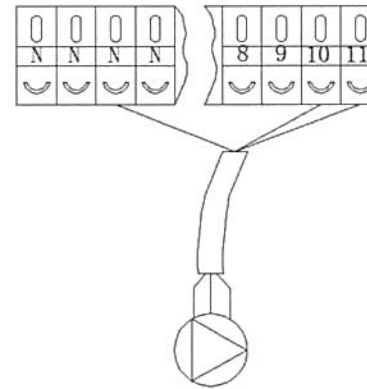

3#Electromagnetic 3-way valve

### 2) For Water Pump

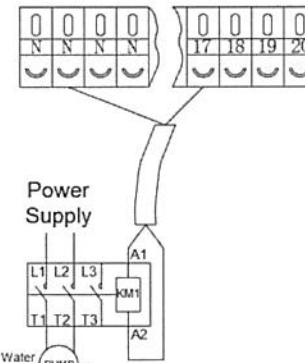

Lower Return Water Pump

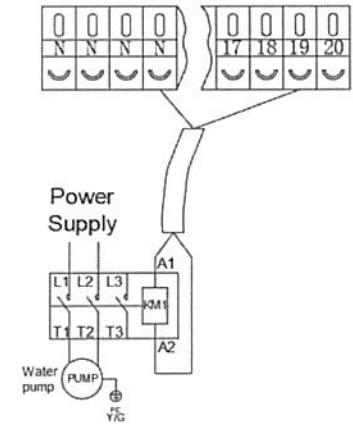

Mixing Water Pump

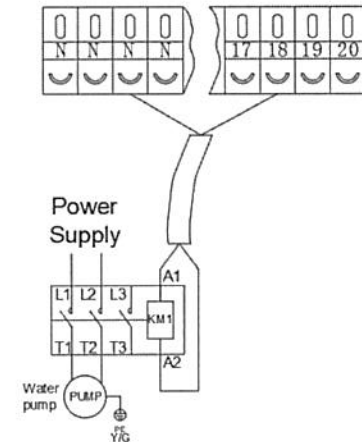

Solar Pump

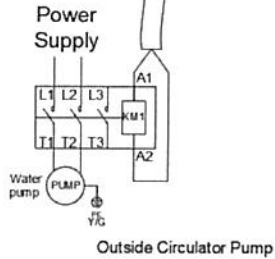
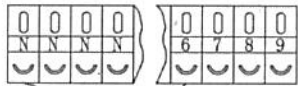

Voltage	220-240VAC
Maximum current	0.2A
Wire Specifications	20AWG/0.75mm <sup>2</sup>
Control Method	Type 2

### 3) Electric heater for water tank

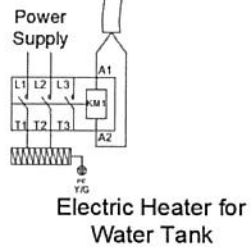
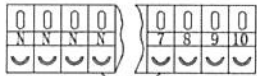

Voltage	220-240VAC
Maximum current	0.2
Wire Specifications	20AWG/0.75mm <sup>2</sup>
Control Method	Type 2

### 4) For Thermostat

"Power input" provides the voltage of "thermostat", and does not directly supply power to the motherboard interface.

Port "L1" supplies 220V to the RT connector.

Port "L1" is connected to single-phase power from the unit's main power port L.

There are three methods of connecting the thermostat cable (as pictured above), depending on the application.

**Method 1** When "thermostat control" is set to "single zone mode switch":

When the signal C is closed, zone A starts cooling operation;

When the C signal is disconnected and the H signal is closed, zone A starts heating operation;

When both the C signal and the H signal are disconnected, the A area is closed;

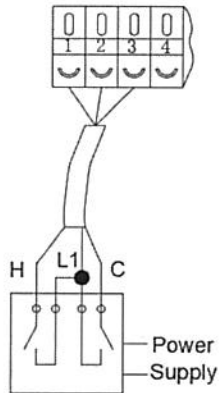

Method 1

(Single Zone Mode Switch)

**Method 2** When "thermostat control" is set to "single zone switch":

When the C signal is closed, the A area is open;

When the C signal is disconnected, the A area is closed;

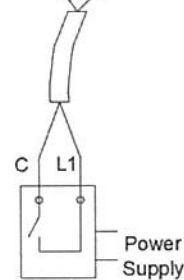

Method 2  
(Single Zone Switch)

**Method 3** When "thermostat control" is set to "dual zone switch":

When the C signal is closed, the A area is opened; when the C signal is disconnected, the A area is closed;

When the H signal is closed, the B area is opened; when the H signal is disconnected, the B area is closed;

(Note: Zone B is only used for heating operation)

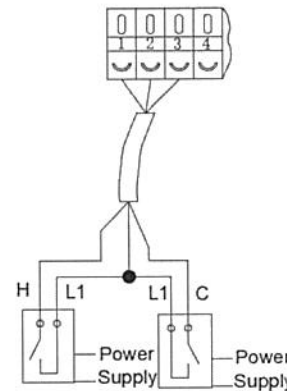

Method 3  
(dual zone switch)

Voltage	220-240VAC
Maximum Current	0.2A
Wire Specifications	20AWG/0.75mm <sup>2</sup>

### 5) For Signal Output, External Heat Source

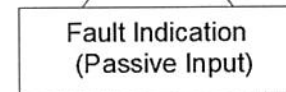
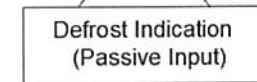



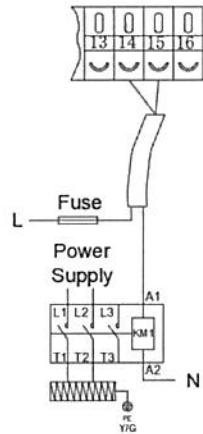

External Heat Source

Voltage	220-240VAC
Maximum Current	0.2A
Wire Specifications	20AWG/0.75mm <sup>2</sup>
Control Method	Type 1

#### 6) For Wire Control Switch

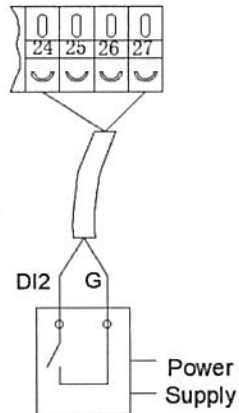

#### For Smart Grid

The smart grid wiring is shown in the figure below, SG is the smart grid signal, EVU is the photovoltaic signal.

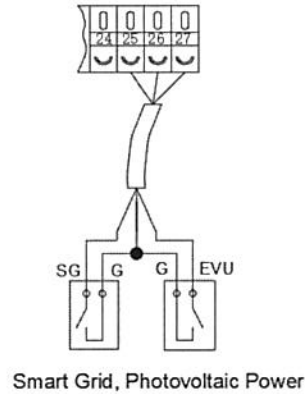

#### 7) For Solar Signal (220V power input, L and N)

When [solar temperature probe] is set to "disabled", it is necessary to connect the solar signal to control the start and stop of the solar water pump. The wiring is shown in the figure below.

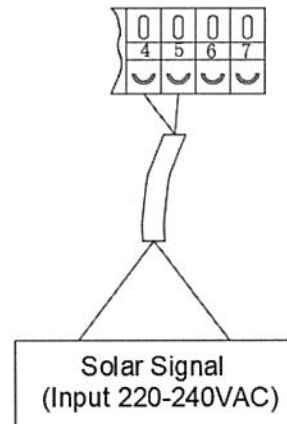

### 3.3. Trial After Installation

#### WARNING

Please check all the wiring carefully before turning on the heat pump.

#### 3.3.1. Inspection Before Trial Running

Before the running test, confirm the below items and write √ in the block;

<input type="checkbox"/>	Correct unit installation
<input type="checkbox"/>	The power supply voltage is the same as unit rated voltage
<input type="checkbox"/>	Correct piping and wiring
<input type="checkbox"/>	The air inlet & outlet port of the unit is unblocked
<input type="checkbox"/>	Drainage and venting are unblocked and no water leaking
<input type="checkbox"/>	The leakage protector is working
<input type="checkbox"/>	Piping insulation is working
<input type="checkbox"/>	The ground wire is connected correctly

#### 3.3.2. Trial Running

Step 1: Running test can begin after completing all installation;

Step 2: All wiring and piping should be connected well and carefully checked, then fill the water tank with water before power is switched on;

Step 3: Emptying all air within pipes and water tank, press the "ON/OFF" button on the control panel to run the unit at setting temperature;

Step 4: Items need to be checked during the running test:

- ① During the first running, the unit current is normal or not;
- ② Each function button on the control panel is normal or not;
- ③ Display screen is normal or not;
- ④ Is there any leakage in the whole heating circulation system;
- ⑤ Condensate drain is normal or not;
- ⑥ Are there any abnormal sounds or vibrations during running.

## 4. MAINTENANCE AND WINTERIZATION

### 4.1. Maintenance

**⚠ WARNING**

Before undertaking maintenance work on the unit, ensure that you have disconnected the electrical power supply.

● **Cleaning**

- The heat pump's casing must be cleaned with a damp cloth. The use of detergents or other household products could damage the surface of the casing and affect its properties.
- The evaporator at the rear of the heat pump must be carefully cleaned with a vacuum cleaner and soft brush attachment.

● **Annual maintenance**

The following operations must be undertaken by a qualified person at least once a year.

- Carry out safety checks.
- Check the integrity of the electrical wiring.
- Check the earthing connections.
- Monitor the state of the pressure gauge and the presence of refrigerant.

### 4.2. Winterizing

● **"CUT OFF" power supply of the heater before cleaning, examination and repairing**

When you don't use:

- Cut off the power supply to prevent any mechanical damage.
- Drain water clear of the machine.
- Cover the machine body when not in use.

- **NOTE: Unscrew the water nozzle of the inlet pipe to let the water flow out.**

## 5. REMOVAL PROCEDURES FOR OUTDOOR UNITS

### 5.1. Removal Instructions for Outdoor Panels

● **NE-F60HCR4INEM**

**Work Procedure**

**1.Remove the Top Cover**

- Remove the two screws of the top cover.
- Slide the top cover to the right.
- Pull out the top cover upwards

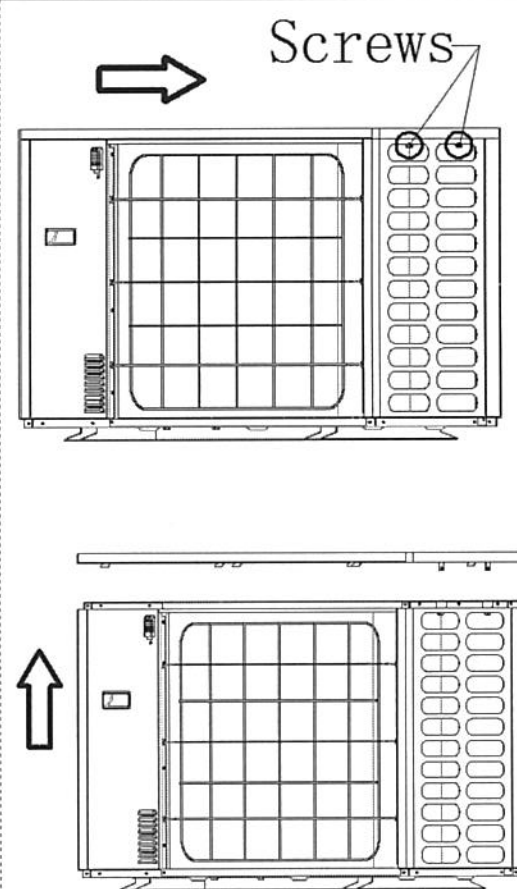

The diagram illustrates the removal of the top cover in three steps. Step 1 shows the top cover with two screws being removed. Step 2 shows the top cover being slid to the right. Step 3 shows the top cover being pulled upwards. The unit is shown from a front-three-quarter view.

## 2.Remove The Front Service Panel

① Remove the six screws in the upper and lower parts of the front service plate.

② Push the front service panel upwards.

③ And then take off the panel as shown.

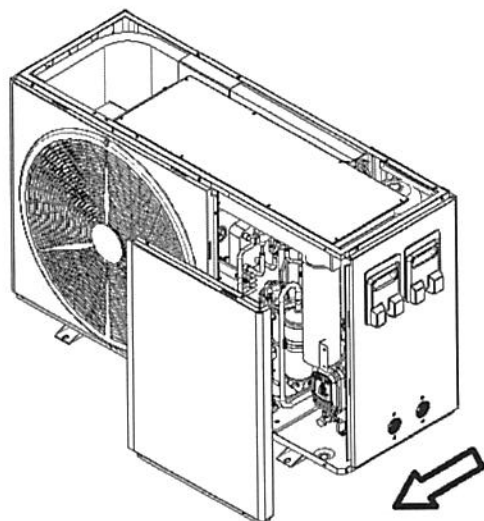
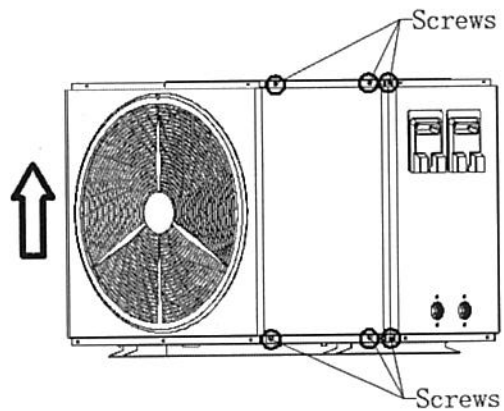

## 3.Remove The Air Guide Panel

① Remove the eleven screws from the side of the air guide panel.

② Remove the left panel by pushing the air guide panel upwards.

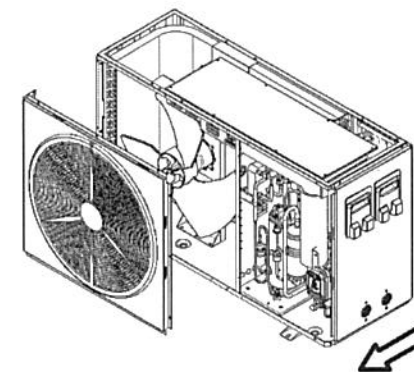
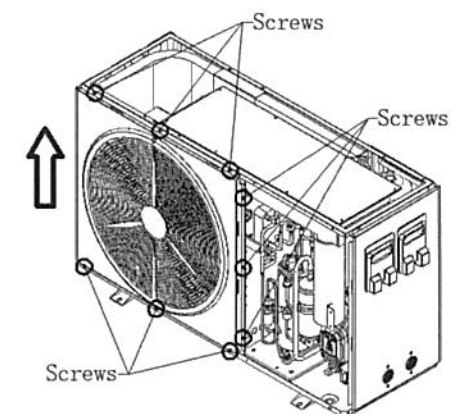
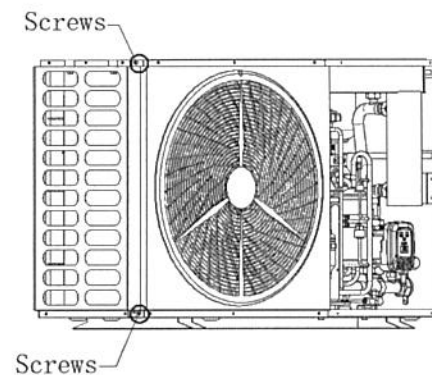



#### 4.Remove The Back Net

① Remove the six screws of the back net.

② Remove the back net.

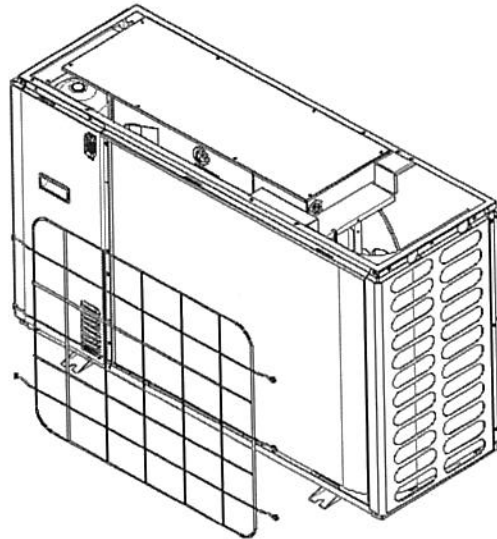
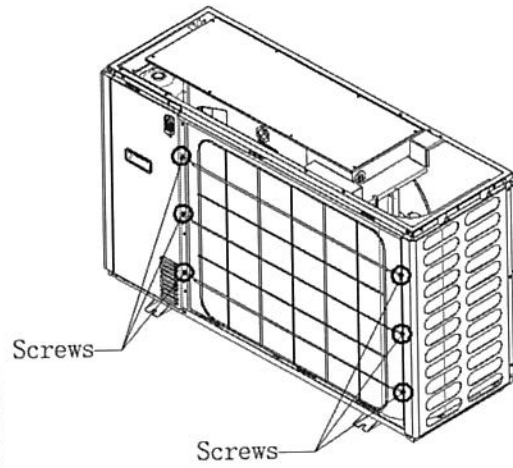

#### 5.Remove The Left Panel

① Remove the seven screws in the left panel.

② Remove the left panel.

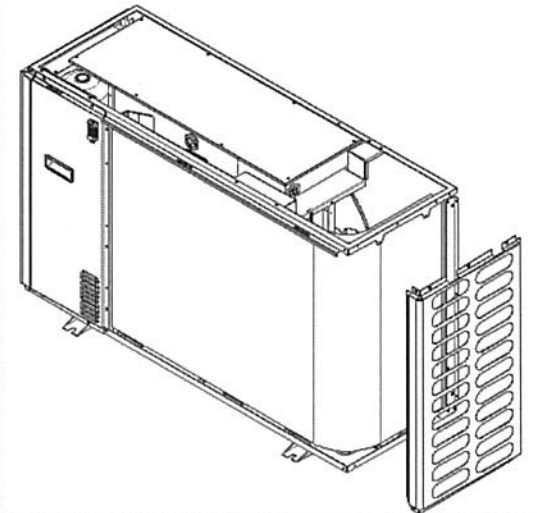
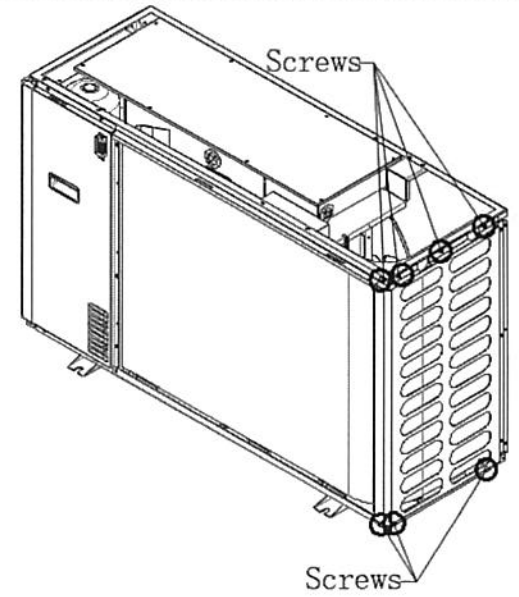

### 6.Remove The Back Service Panel

① Remove the eight screws from the back service panel.

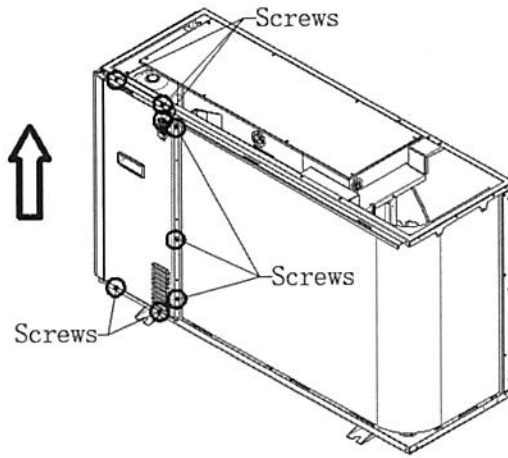

② Remove the back service panel by pushing it upwards .

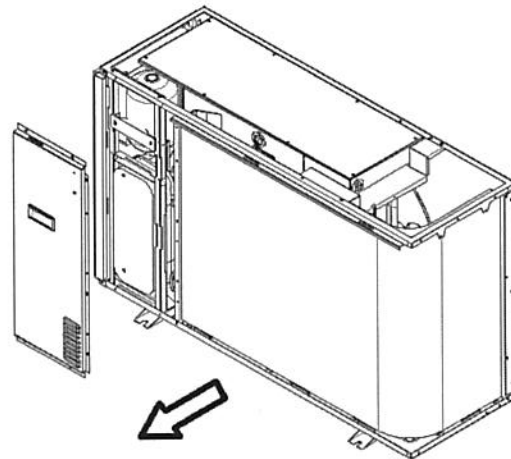

● NE-F90HCR4INEM, NE-F90HCR4TINEM, NE-F130HCR4INEM, NE-F130HCR4TINEM

### Work Procedure

#### 1.Remove the Top Cover

④ Remove the two screws on the right side of the top cover.

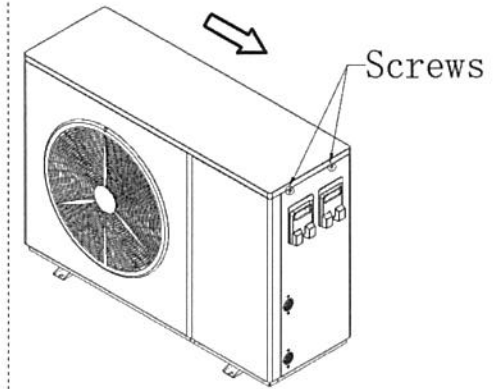

⑤ Slide the top cover to the right.

⑥ Pull out the top cover upwards

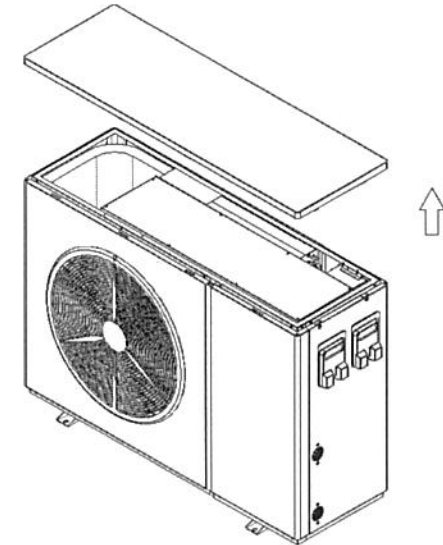

## 2.Remove The Front Service Panel

④ Remove the six screws in the upper and lower parts of the front service plate.

⑤ Push the front service panel upwards.

⑥ And then take off the panel as shown.

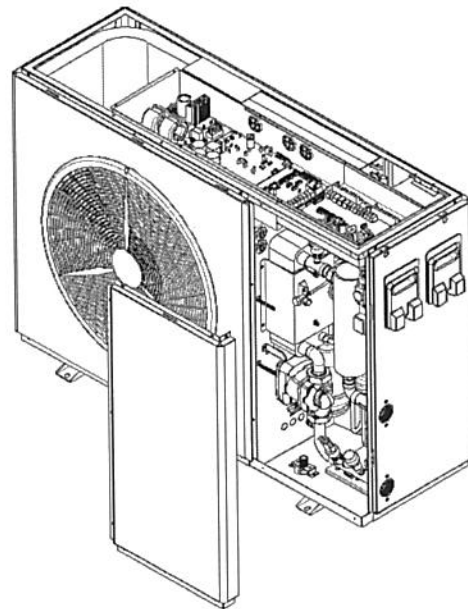
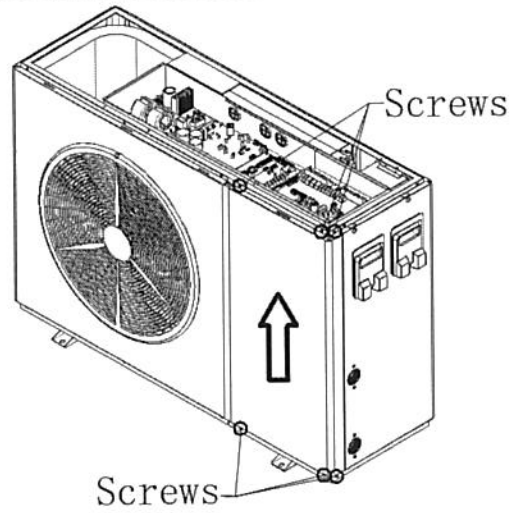

## 3.Remove The Air Guide Panel

③ Remove the nine screws from the side of the air guide panel.

④ Remove the left panel by pushing the air guide panel upwards.

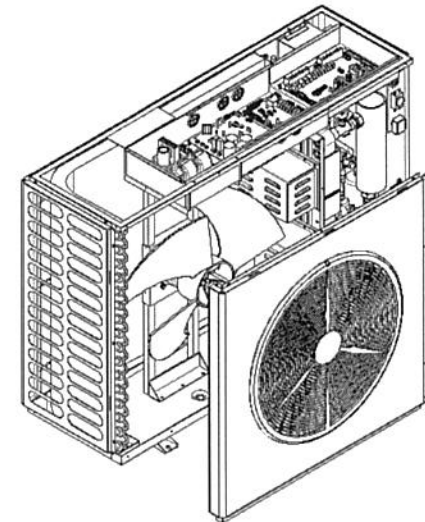
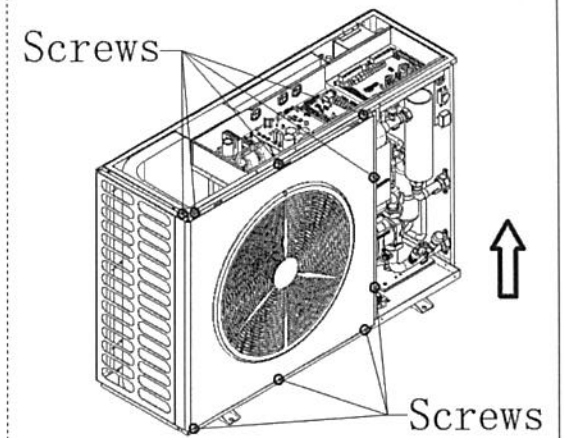



#### 4.Remove The Back Net

③ Remove the six screws of the back net.

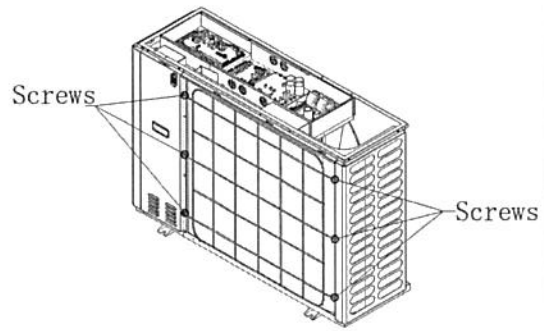

④ Remove the back net.

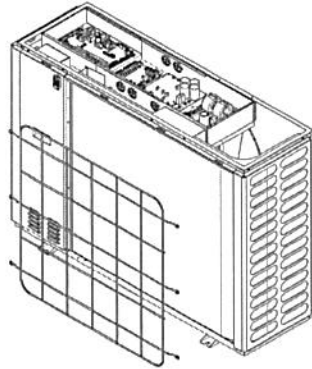

#### 5.Remove The Left Panel

③ Remove the seven screws in the left panel.

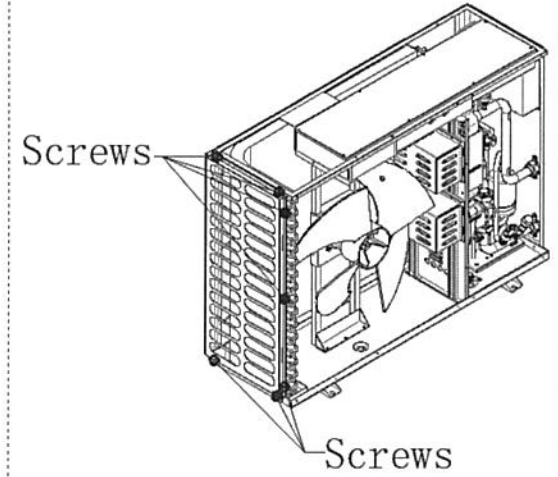

④ Remove the left panel.

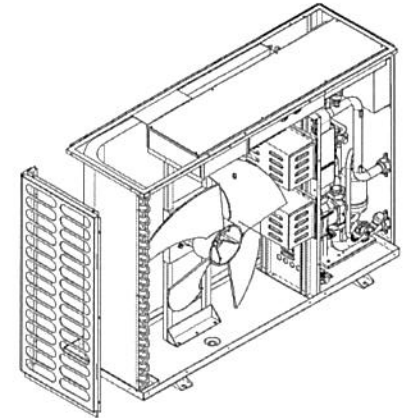

### 6.Remove The Back Service Panel

③ Remove the seven screws from the back service panel.

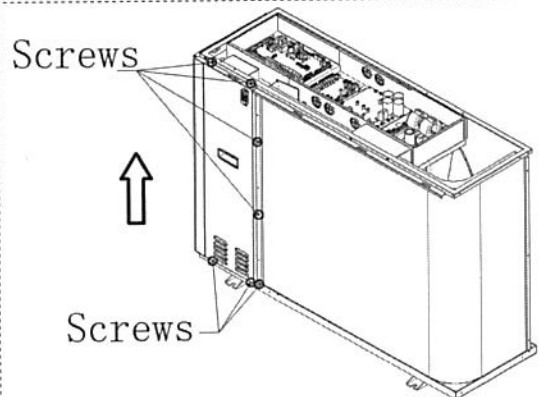

④ Remove the back service panel by pushing it upwards .

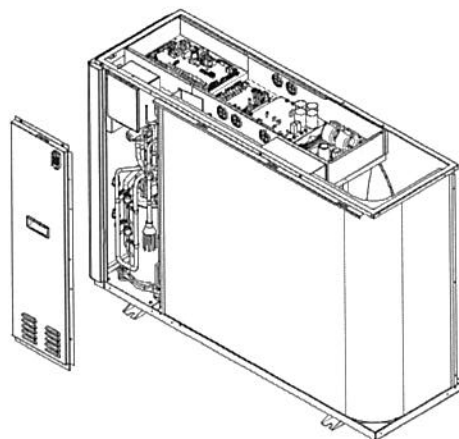

- NE-F160HCR4INEM,NE-F160HCR4TINEM,NE-F185HCR4TINEM,NE-F200HCR4TINEM,NE-F230HCR4TINEM,NE-F260HCR4TINEM

### Work procedure

#### 1.Remove the Top Cover

① Remove the two screws on the left side of the top cover.

② Slide the top cover to the right.

③ Pull out the top cover upwards

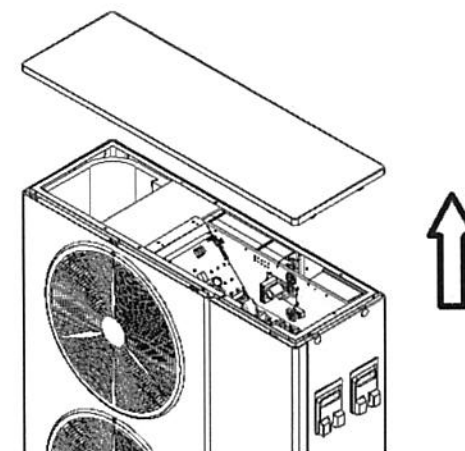
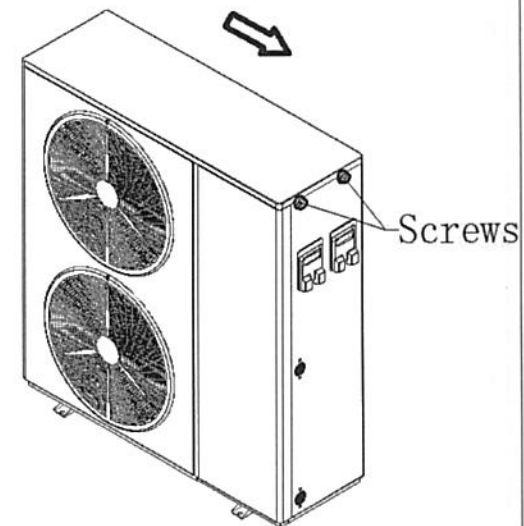

## 2.Remove The Front Service Panel

- ① Remove the four screws in the upper and lower parts of the front service plate.
- ② Push the front service panel upwards.
- ③ And then take off the panel as shown.

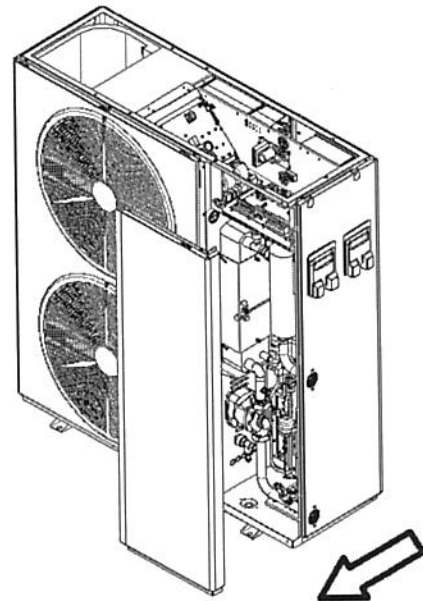
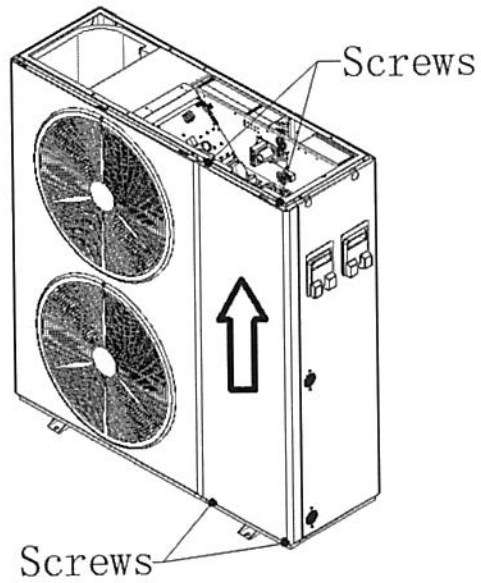

## 3.Remove The Air Guide Panel

- ① Remove the nine screws of the air guide panel.
- ② Pull out the panel upward to remove.

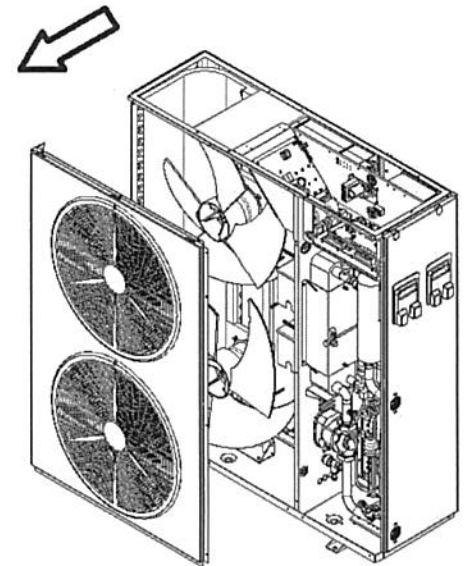
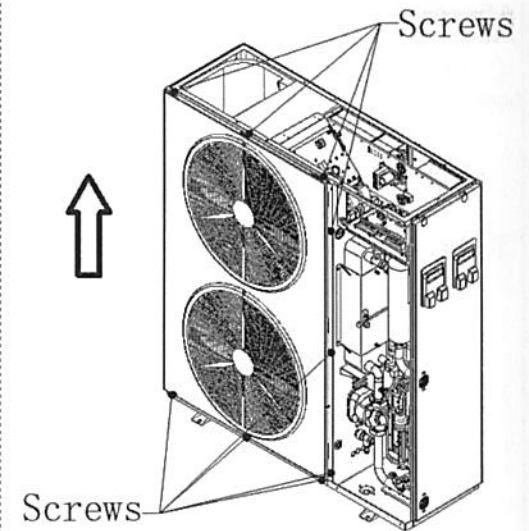



#### 4.Remove The Back Net

① Remove the eight screws of back net.

② Remove the back net.

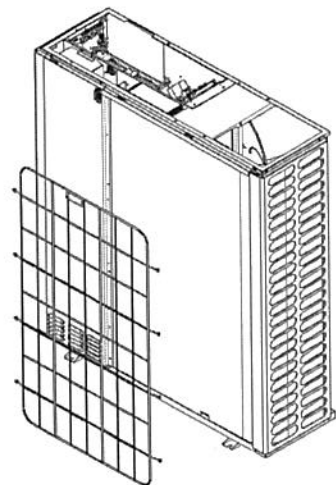
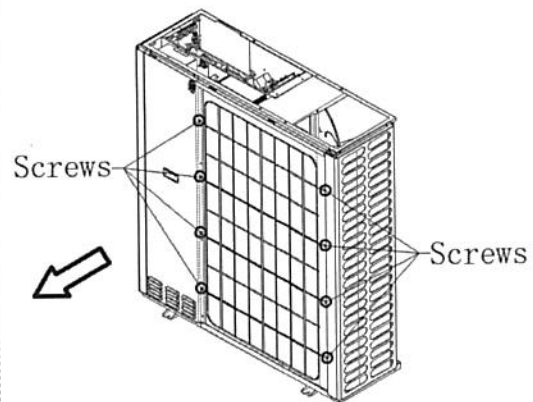

#### 5.Remove The Left Panel

① Remove the six screws in the left panel.

② Remove the left panel.

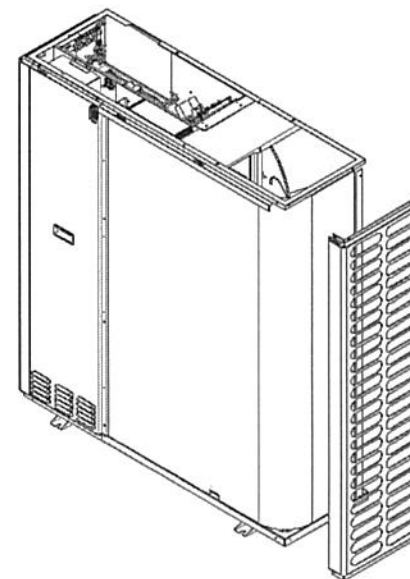
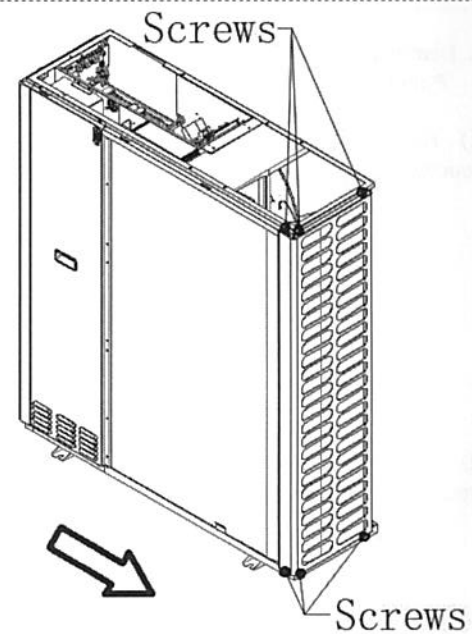

**6. Remove The Back Service Panel**

① Remove the seven screws from the back service panel.

② Remove the back service panel by pushing it upwards.

