

TS0045UK03

RS/1 Series

One Stage Gas Burners



RS 34/1 MZ	70 ÷ 390 kW
RS 44/1 MZ	101 ÷ 550 kW

The RS/1 series of burners covers a firing range from 70 to 550 kW, and they have been designed for use in low or medium temperature hot water boilers, hot air or steam boilers, diathermic oil boilers.

Operation is "one stage"; the burners are fitted with a microprocessor control panel which supplies indication of operation and diagnosis of fault cause. Optimisation of sound emissions is guaranteed by the special design of the air suction circuit.

The elevated performance of the fans and combustion head, guarantee flexibility of use and excellent working at all firing rates.

The exclusive design ensures reduced dimensions, simple use and maintenance. A wide range of accessories guarantees elevated working flexibility.

Technical Data

MODEL		RS 34/1 MZ	One stage	RS 44/1 MZ
Burner operation mode			One stage	
Modulation ratio at max. output			--	
Servomotor	type		--	
	run time s		--	
Heat output	kW	70÷390		101÷550
	Mcal/h	60÷335		87÷473
Working temperature	°C min./max.		0/40	
FUEL/AIR DATA				
Net calorific value G20 gas	kWh/Nm ³		10	
G20 density gas	kg/Nm ³		0,71	
G20 gas delivery	Nm ³ /h	7÷39		10÷55
Net calorific value G25 gas	kWh/Nm ³		8,6	
G25 density gas	kg/Nm ³		0,78	
G25 delivery gas	Nm ³ /h	8÷45		12÷64
Net calorific value LPG gas	kWh/Nm ³		25,8	
LPG gas density	kg/Nm ³		2,02	
LPG gas delivery	Nm ³ /h	3÷15		4÷21
Fan	type		Centrifugal with forward curve blades	
Air temperature	Max. °C		60	
ELECTRICAL DATA				
Electrical supply	Ph/Hz/V		1/50-60/220-230~(±10%)	
Auxiliary electrical supply	Ph/Hz/V		1/50-60/220-230~(±10%)	
Control box	type		RMG	
Total electrical power	kW	0,6		0,7
Auxiliary electrical power	kW	0,3		0,28
Protection level	IP	40		40
Motor electrical power	kW	0,3		0,42
Rated motor current	A	3,2		3,5
Motor start current	A	15		17
Motor protection level	IP	54		54
	type			
Ignition transformer	V1 - V2	230V - 1x15 kV		230V - 1x15 kV
	I1 - I2	1A - 25 mA		1A - 25 mA
Operation			Intermittent (at least one stop every 24 h)	
EMISSIONS				
Sound pressure	dBA	70		72
Sound power	W	--		--
CO Emission	mg/kWh		< 40	
NOx Emission	mg/kWh		< 120	
APPROVAL				
Directive		90/396 - 89/336 (2004/108) - 73/23 (2006/95) - 92/42 EC		
Conforming to		EN 676		
Certification		CE 0085BR0380		CE 0085BR0380

Reference conditions:

Temperature: 20°C - Pressure: 1013,5 mbar - Altitude: 0 m a.s.l. - Noise measured at a distance of 1 meter.

Since the Company is constantly engaged in the production improvement, the aesthetic and dimensional features, the technical data, the equipment and the accessories can be changed. This document contains confidential and proprietary information of RIELLO S.p.A. Unless authorised, this information shall not be divulged, nor duplicated in whole or in part.

FIRING RATES

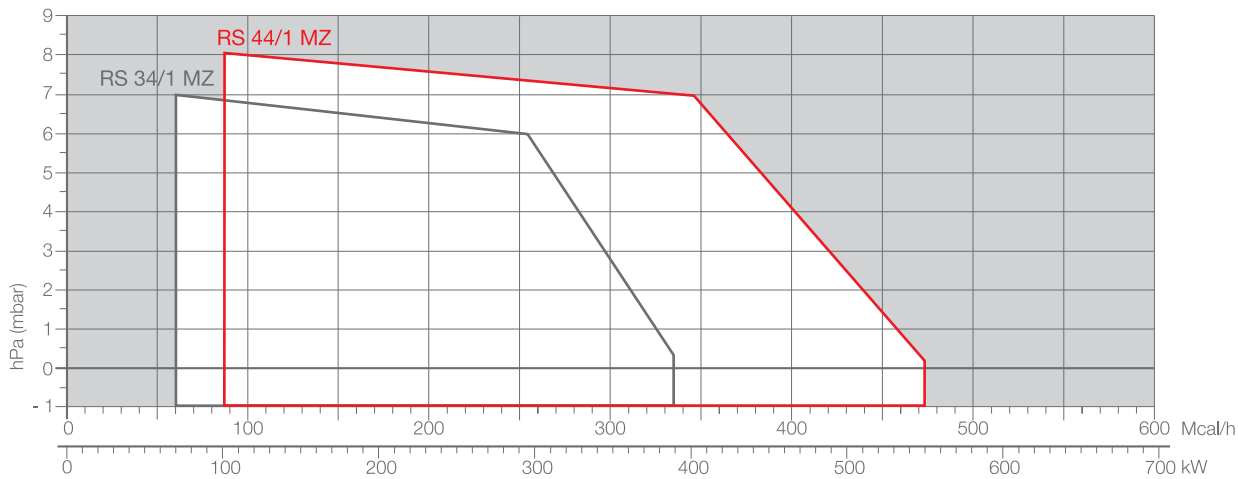

 Useful working field for choosing the burner

Test conditions conforming to EN 676:
 Temperature: 20°C
 Pressure: 1013,5 mbar
 Altitude: 0 m a.s.l.



GAS TRAINS

Fuel can be supplied either from the right or left hand sides.

The gas train can be selected to best fit system requirements depending on the fuel output and pressure in the supply line.

The gas train can be “Multibloc” type (containing the main components in a single unit) or “Composed” type (assembly of the single components).

The gas train can be, also, “One stage” or “Two stage” type. Conforming to EN676 Standard the one stage gas train can be used up to a capacity of 350 kW.



Example of the gas train connection flange of RS/1 burners.

MULTIBLOC gas train without seal control

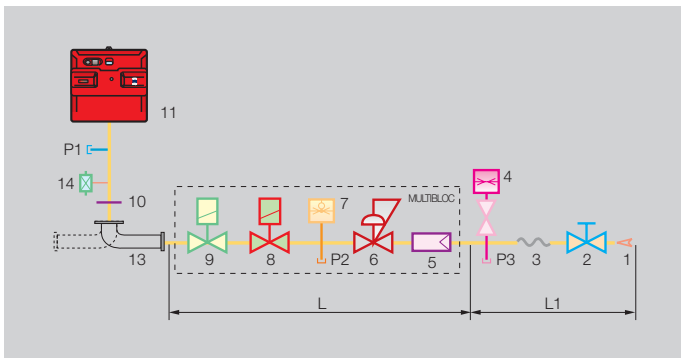

MULTIBLOC gas train with seal control

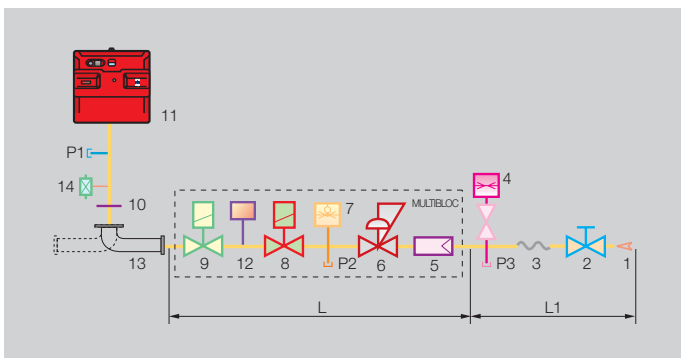

COMPOSED gas train without seal control

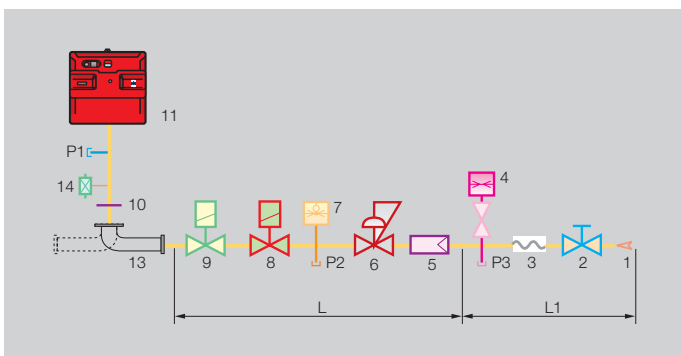

- | | |
|----|--|
| 1 | Gas input pipework |
| 2 | Manual valve |
| 3 | Anti-vibration joint |
| 4 | Pressure gauge with pushbutton cock |
| 5 | Filter |
| 6 | Pressure regulator (vertical) |
| 7 | Minimum gas pressure switch |
| 8 | VS safety solenoid (vertical) |
| | VR regulation solenoid (vertical) |
| 9 | Two settings: - firing output (rapid opening)
- maximum output (slow opening) |
| 10 | Gasket and flange supplied with the burner |
| 11 | Burner |
| 12 | Seal control mechanism for valves 8-9. According to standard EN 676, the seal control is compulsory for burners with maximum output above 1200 kW. |
| 13 | Gas train-burner adapter |
| 14 | Maximum gas pressure switch (present if installed as burner accessory) |
| P1 | Combustion head pressure |
| P2 | Pressure downstream from the regulator |
| P3 | Pressure upstream from the filter |
| L | Gas train supplied separately, with the code given in the table |
| L1 | Installer's responsibility |

COMPOSED gas train with seal control

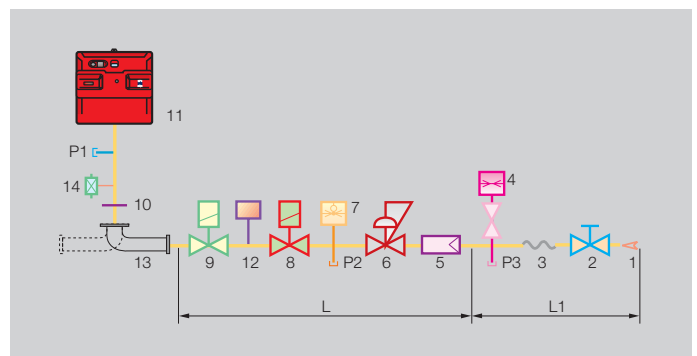

Gas trains are approved by standard EN 676 together with the burner.

The overall dimensions of the gas train depends on how they are constructed. The following table shows the maximum dimensions of the gas trains that can be fitted to RS/1 burners, intake and outlet diameters and seal control if fitted.

Please note that the seal control can be installed as an accessory, if not already installed on the gas train.

The maximum gas pressure of gas train "Multibloc" type is 360 mbar, and that one of gas train "Composed" type is 500 mbar.

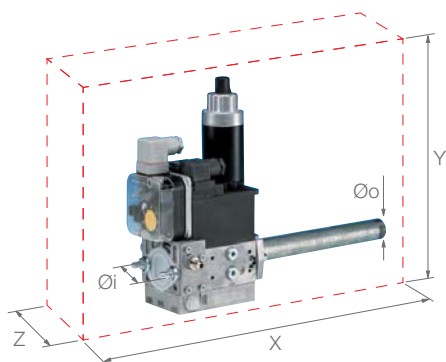

Example of gas train "MULTIBLOC" type without seal control

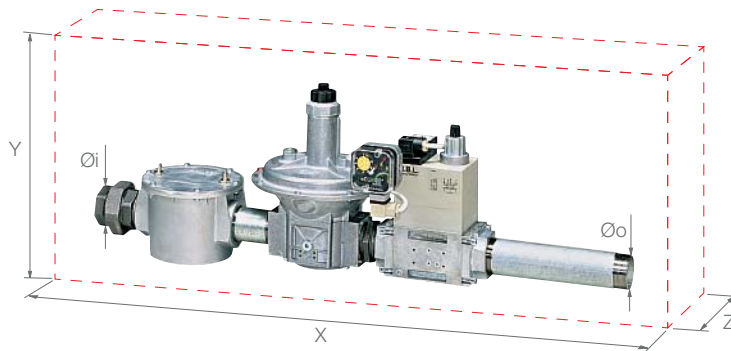

Example of gas train "COMPOSED" type without seal control

		NAME	CODE	Ø i	Ø o	X mm	Y mm	Z mm	OUTPUT PRESSURE RANGE (mbar)	SEAL CONTROL
ONE STAGE GAS TRAINS	MULTIBLOC GAS TRAINS	MBD 405	3970500 (1) 3970553 (1)	3/4"	3/4"	371	186	120	4 - 20	Accessory
		MBD 407	3970229 (2) 3970599 (1)(3) 3970554 (1)	3/4"	3/4"	371	196	120	4 - 20	Accessory
		MBD 410	3970230 (2) 3970600 (1)(3) 3970144 (1)	1"	3/4"	405	217	145	4 - 20	Accessory
		MBD 412	3970231 (2) In progress (1)(3)	1"1/4	1"1/4	433	217	145	4 - 20	Accessory
		MBD 412 CT	3970197 (1) 3970180 (1)	1"1/4	1"1/4	433	217	262	4 - 20	Incorporated
		MBD 415	3970232 (2) 3970250 (1)(3)	1"1/2	1"1/2	523	250	100	4 - 33	Accessory
		MBD 415 CT	3970198 (1) 3970253 (1)(3)	1"1/2	1"1/2	523	250	227	4 - 33	Incorporated
		MBD 420	3970181 (1) 3970233 (2) 3970182 (1)	2"	2"	523	300	100	4 - 33	Accessory
		MBD 420 CT	3970234 (2) 3970252 (1)(3)	2"	2"	523	300	227	4 - 33	Incorporated
TWO STAGE GAS TRAINS	MULTIBLOC GAS TRAINS	MBZRDLE 407	3970046 (1)	3/4"	3/4"	371	256	120	4 - 20	-
		MBZRDLE 410	3970079 (1)	1"	3/4"	405	315	145	4 - 20	-
		MBZRDLE 412	3970152 (1)	1"1/4	1"1/4	433	315	145	4 - 20	-
		MBZRDLE 415	3970183 (1)	1"1/2	1"1/2	523	350	100	4 - 33	-
		MBZRDLE 420	3970184 (1)	2"	2"	523	410	100	4 - 33	-
		MBZRDLE 420 CT	3970185 (1)	2"	2"	523	410	227	4 - 33	Incorporated

(1) Gas Train with 6-pin plug to install for connection to the burner.
 (2) Gas Train with 6-pin plug installed for connection to the burner.

(3) Gas Train S52 type for application with high combustion head pressure drop.

PRESSURE DROP DIAGRAM

The diagrams indicate the minimum pressure drop of the burners with the various gas trains that can be matched with them; at the value of these pressure drop add the combustion chamber pressure. The value thus calculated represents the minimum required input pressure to the gas train.

RS 34/1 MZ (NATURAL GAS)

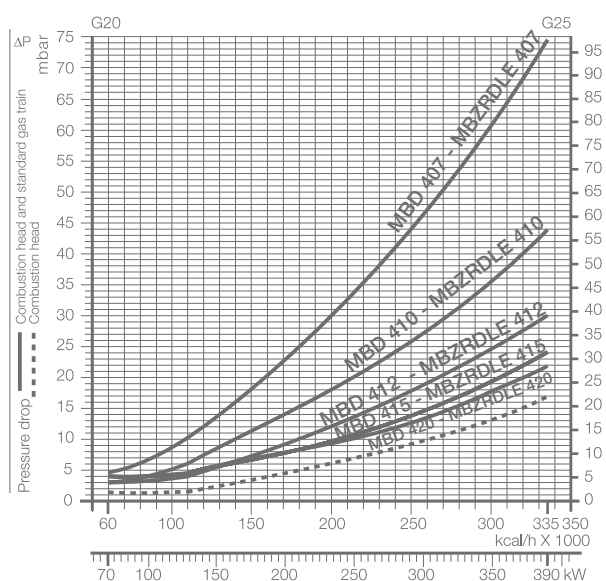

GAS TRAIN	CODE	ADAPTER	SEAL CONTROL
MBD 405	3970500 (1)	3000824	Accessory
	3970553 (1)	3000824	Accessory
MBD 407	3970229 (2)	3000824	Accessory
	3970599 (1)(3)	3000824	Accessory
MBZRDL 407	3970046 (1)	3000824	Accessory
	3970554 (1)	3000824	Accessory
MBD 410	3970230 (2)	3000824	Accessory
	3970600 (1)(3)	3000824	Accessory
MBZRDL 410	3970079 (1)	3000824	Accessory
MBD 412	3970144 (1)	--	Accessory
	3970231 (2)	--	Accessory
MBD 412 CT	3970197 (1)	-	Incorporated

(1) Gas Train with 6-pin plug to install for connection to the burner.

(2) Gas Train with 6-pin plug installed for connection to the burner.

RS 34/1 MZ (LPG)

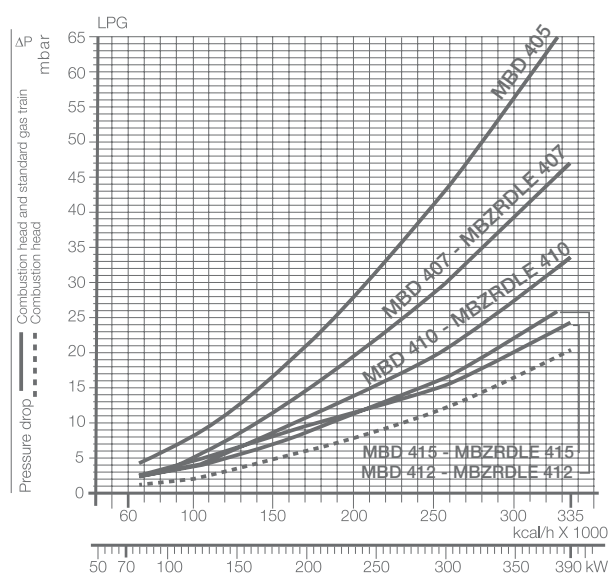

GAS TRAIN	CODE	ADAPTER	SEAL CONTROL
MBZRDL 412	3970152 (1)	-	Accessory
MBD 415	3970180 (1)	--	Accessory
	3970232 (2)	--	Accessory
MBD 415 CT	3970198 (1)	--	Incorporated
	3970253 (1)(3)	--	Incorporated
MBZRDL 415	3970183 (1)	-	Accessory
MBD 420	3970181 (1)	3000822	Accessory
	3970233 (2)	3000822	Accessory
MBD 420 CT	3970182 (1)	3000822	Incorporated
	3970234 (2)	3000822	Incorporated
	3970252 (1)(3)	3000822	Incorporated
MBZRDL 420	3970184 (1)	3000822	Accessory
MBZRDL 420 CT	3970185 (1)	3000822	Incorporated

(3) Gas Train S52 type for application with high combustion head pressure drop.

RS 44/1 MZ (NATURAL GAS)

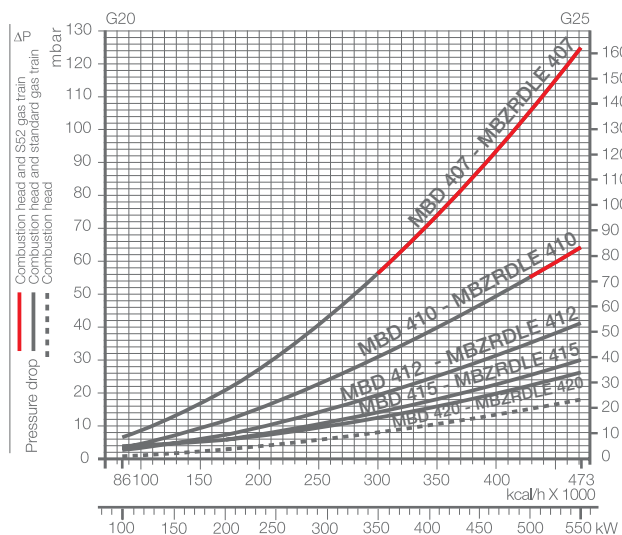

GAS TRAIN	CODE	ADAPTER	SEAL CONTROL
MBD 405	3970500 (1)	3000824	Accessory
	3970553 (1)	3000824	Accessory
MBD 407	3970229 (2)	3000824	Accessory
	3970599 (1)(3)	3000824	Accessory
MBZRDLE 407	3970046 (1)	3000824	Accessory
	3970554 (1)	3000824	Accessory
MBD 410	3970230 (2)	3000824	Accessory
	3970600 (1)(3)	3000824	Accessory
MBZRDLE 410	3970079 (1)	3000824	Accessory
MBD 412	3970144 (1)	--	Accessory
	3970231 (2)	--	Accessory
MBD 412 CT	3970197 (1)	-	Incorporated
MBZRDLE 412	3970152 (1)	-	Accessory
	3970180 (1)	-	Accessory

(1) Gas Train with 6-pin plug to install for connection to the burner.
 (2) Gas Train with 6-pin plug installed for connection to the burner.

RS 44/1 MZ (LPG)

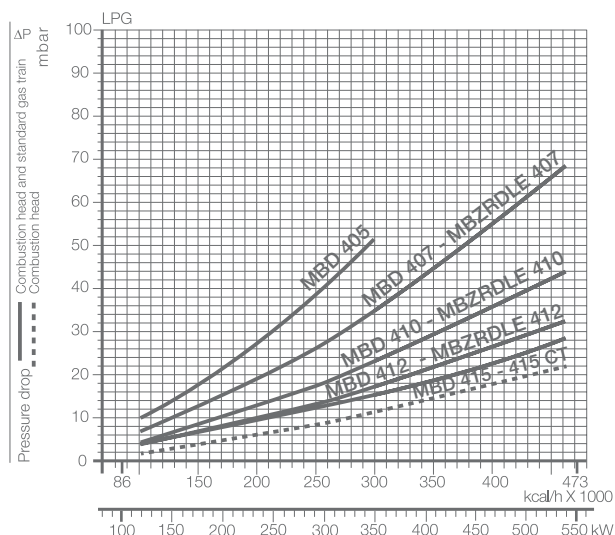

GAS TRAIN	CODE	ADAPTER	SEAL CONTROL
MBD 415	3970232 (2)	-	Accessory
	3970250 (1)(3)	-	Accessory
MBD 415 CT	3970198 (1)	--	Incorporated
MBZRDLE 415	3970253 (1)(3)	--	Incorporated
MBZRDLE 415	3970183 (1)	-	Accessory
MBD 420	3970181 (1)	3000822	Accessory
	3970233 (2)	3000822	Accessory
MBD 420 CT	3970182 (1)	3000822	Incorporated
	3970234 (2)	3000822	Incorporated
	3970252 (1)(3)	3000822	Incorporated
MBZRDLE 420	3970184 (1)	3000822	Accessory
MBZRDLE 420 CT	3970185 (1)	3000822	Incorporated

(3) Gas Train S52 type for application with high combustion head pressure drop.

Please contact the Riello Burner Technical Office for different pressure levels from those above indicated and refer to the technical manual for the correct choice of the spring.

SELECTING THE FUEL SUPPLY LINES

The following diagram enables pressure drop in a pre-existing gas line to be calculated and to select the correct gas train.

The diagram can also be used to select a new gas line when fuel output and pipe length are known. The pipe diameter is selected on the basis of the desired pressure drop. The diagram uses methane gas as reference; if another gas is used, conversion coefficient and a simple formula (on the diagram) transform the gas output to a methane equivalent (refer to figure A). Please note that the gas train dimensions must take into account the back pressure of the combustion chamber during operations.

Control of the pressure drop in an existing gas line or selecting a new gas supply line.

The methane output equivalent is determined by the formula fig. A on the diagram and the conversion coefficient.

Once the equivalent output has been determined on the delivery scale (\dot{V}), shown at the top of the diagram, move vertically downwards until you cross the line that represents the pipe diameter; at this point, move horizontally to the left until you meet the line that represents the pipe length.

Once this point is established you can verify, by moving vertically downwards, the pipe pressure drop of on the bottom scale below (mbar).

By subtracting this value from the pressure measured on the gas

meter, the correct pressure value will be found for the choice of gas train.

Example:

- gas used G25
- gas output 9.51 mc/h
- pressure at the gas meter 20 mbar
- gas line length 15 m
- conversion coefficient 0.62 (see figure A)

- equivalent methane output $\dot{V} = \left[\begin{array}{l} 9.51 \\ 0.62 \end{array} \right] = 15.34 \text{ mc/h}$

- once the value of 15.34 has been identified on the output scale (\dot{V}), moving vertically downwards you cross the line that represents 1" 1/4 (the chosen diameter for the piping);
- from this point, move horizontally to the left until you meet the line that represents the length of 15 m of the piping;
- move vertically downwards to determine a value of 1.4 mbar in the pressure drop bottom scale;
- subtract the determined pressure drop from the meter pressure, the correct pressure level will be found for the choice of gas train;

- correct pressure = (20-1.4) = 18.6 mbar

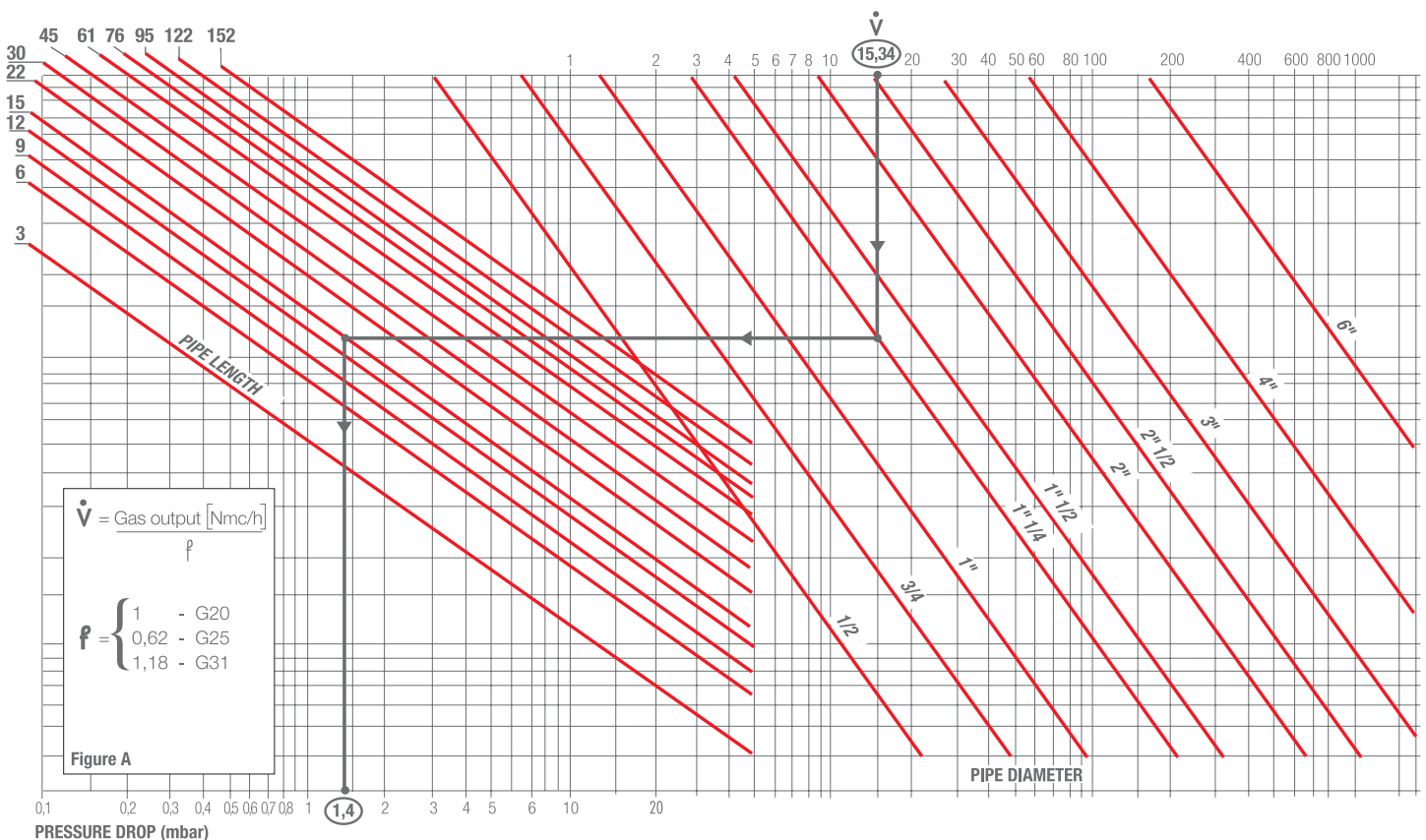

Ventilation

The ventilation circuit produces low noise levels with high performance pressure and air output, inspite of the compact dimensions.

The RS 34-44/1 MZ models, noise has been reduced by the special design of the air suction circuit.

The RS 34/1 MZ and RS 44/1 MZ are realised with a new structure made by an innovative technology based on a new fibreglass reinforced polyamide material, with high thermal and mechanical characteristics, instead of the traditional aluminium.

This allows big advantages in terms of lay-out rationalisation, weight and dimensions reduction.

In order to guarantee the correct exercise temperature for the internal burner components in every working conditions, the new structure includes an innovative patented cooling technology.

Between the burner front base and the reinforcing steel front plate, had been create an air cavity offering an high thermal insulation against the front boiler reflection heat, and to further improve the insulation efficiency the innovative **HCS (Housing Cooling System)** technology had been developed. Inside the front base cavity an air circulation is activated with continuous air volume refresh to obtain an active cooling system and avoid any heat transfer to the electrical component housing.



Example of HCS (Housing Cooling System) working concept.

Different lengths of the combustion head can be chosen for the RS/1 series of burners.

The choice depends on the thickness of the front panel and the type of boiler.

Depending on the type of generator, check that the penetration of the head into the combustion chamber is correct.

The internal positioning of the combustion head can easily be adjusted to the maximum defined output by adjusting a screw fixed to the flange.

Combustion Head

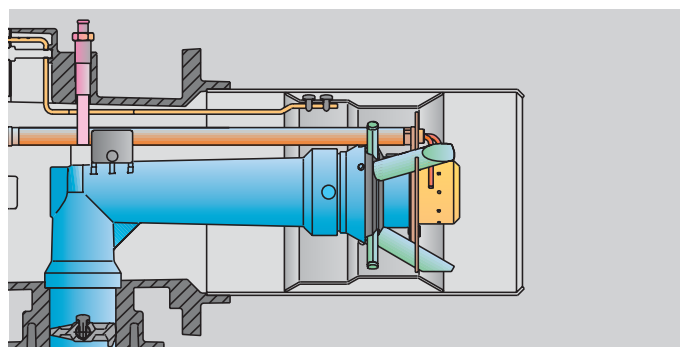

Example of a RS/1 burner combustion head.

DIMENSIONS OF THE FLAME

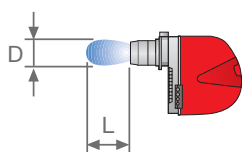

Example:
 Burner thermal output = 500 kW;
 L_{flame} (m) = 1,3 m (medium value);
 D_{flame} (m) = 0,45 m (medium value)

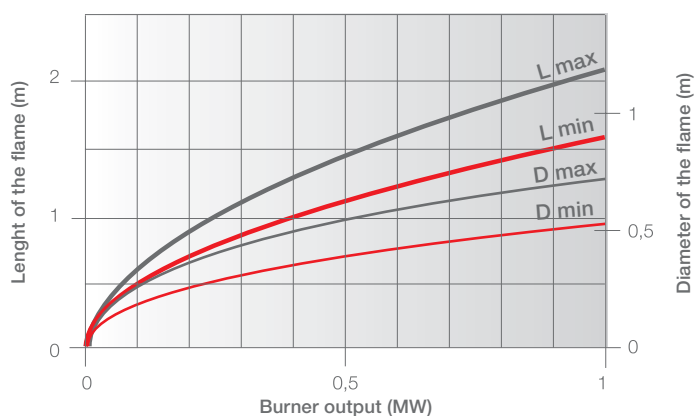



Operation

BURNER OPERATION MODE

The burner of RS/1 series is one stage working.

On “one stage” operation, the burner adjusts output to the requested level, by varying between on-off phases (see picture A).

“ONE STAGE” OPERATION

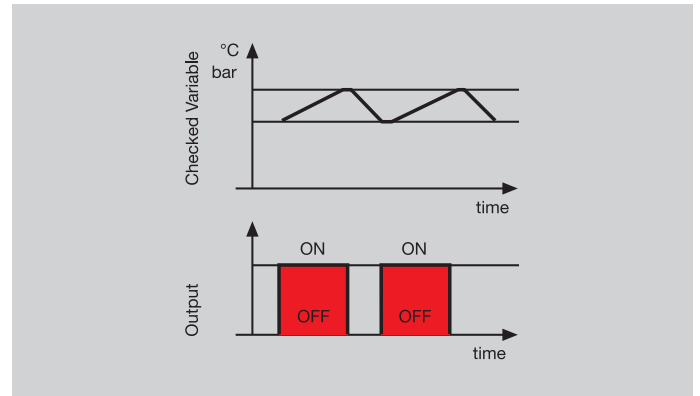

Picture A

All RS/1 series burners are fitted with a new microprocessor control panel for the supervision during intermittent operation. For helping the commissioning and maintenance work, there are two main elements:



The lock-out reset button is the central **operating element** for resetting the burner control and for activating / deactivating the diagnostic functions.

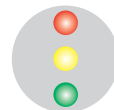

The multi-color LED is the central **indication element** for visual diagnosis and interface diagnosis.

Both elements are located under the transparent cover of lock-out reset button, as showed below.



There are two diagnostic choices, for indication of operation and diagnosis of fault cause:

VISUAL DIAGNOSIS

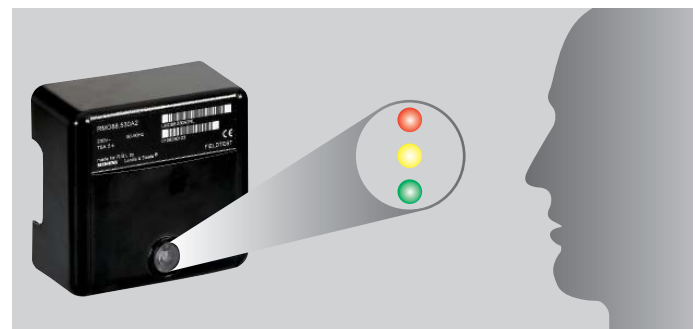

INTERFACE DIAGNOSIS

by the interface adapter and a PC with dedicated software or by a predisposed flue gas analyzer (see paragraph accessories).

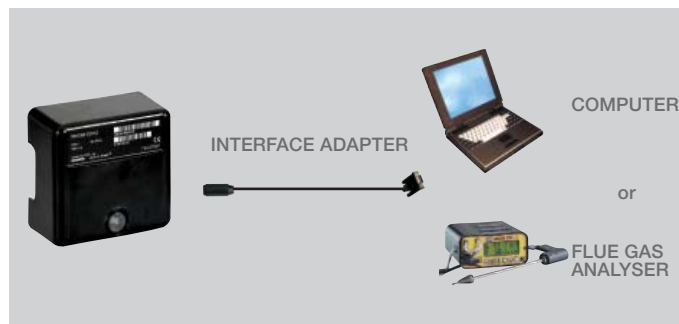

INDICATION OF OPERATION

In normal operation, the various status are indicated in the form of colour codes according to the table below. The interface diagnosis (with adapter) can be activated by pressing the lock-out button for > 3 seconds.

COLOR CODE TABLE	
Operation status	Color code table
Stand-by	● ● ● ● ● ● ● ●
Pre-purging	● ● ● ● ● ● ● ●
Ignition phase	● ● ● ● ● ● ● ●
Flame OK	● ● ● ● ● ● ● ●
Poor flame	● ● ● ● ● ● ● ●
Undervoltage, built-in fuse	● ● ● ● ● ● ● ●
Fault, alarm	● ● ● ● ● ● ● ●
Flame simulation	● ● ● ● ● ● ● ●

● LED off

DIAGNOSIS OF FAULT CAUSES

After lock-out has occurred, the red signal lamp is steady on. In this status, the visual fault diagnosis according to the error code table can be activated by pressing the lock-out reset button for > 3 seconds. The interface diagnosis (with adapter) can be activated by pressing again the lock-out button for > 3 seconds.

The flashing of red LED are a signal with this sequence:

(e.g. signal with n° 3 flashes – faulty air pressure monitor)



ERROR CODE TABLE

POSSIBLE CAUSE OF FAULT	FLASH CODE
No establishment of flame at the end of safety time: - faulty or soiled fuel valves - faulty or soiled flame detector - poor adjustment of burner, no fuel - faulty ignition equipment	● 2x flashes
Faulty air pressure monitor	● 3x flashes
Extraneous light or simulation of flame on burner start up	● 4x flashes
Loss of flame during operation: - faulty or soiled fuel valves - faulty or soiled flame detector - poor adjustment of burner	● 7x flashes
Wiring error or internal fault	● 10x flashes

START UP CYCLE

RS 34/1 MZ - 44/1 MZ

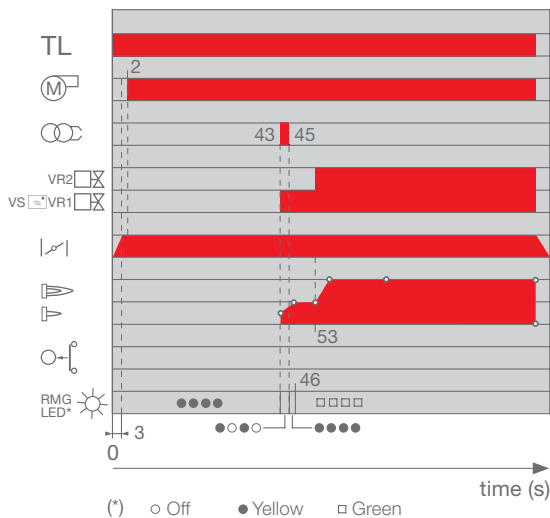

- 0 s The burner begins the firing cycle.
- 2 s The motor starts: pre-purge phase.
- 43 s Ignition electrode sparks; safety valve VS and adjustment valve VR open.
- 45 s The spark goes out.
- 53 s Output can be increased; start up cycle is concluded.

Burner Wiring

All models of the RS/1 burner series have an easily accessible control panel for the electrical components housing and wiring.

Thanks to the new structure concept, they have an extremely clean electrical layout to optimise the commissioning and maintenance speed.

On these models the electrical connections are done by a Plug&Socket system, accessible from the external of the cover, and some of the main components as the air pressure switch and the gas max pressure switch (accessory) are connected to the burner electrical wiring through plugs & sockets system in order to facilitate the connection in case of maintenance.

The electrical wiring of all RS/1 burner models are very easy to do following the wiring diagrams included in the instruction handbook.

Electrical connections must be made by qualified and skilled personnel, according to the local norms.

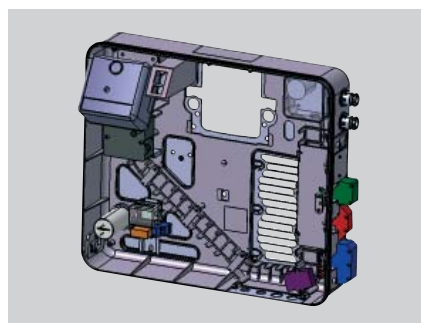

Example of electrical components housing and Plug&Socket system for electrical connection of RS 34-44/1 MZ.

The following table shows the supply lead sections and the type of fuse to be used.

MODEL	V	F (A)	L (mm ²)
► RS 34/1 MZ	230	T6	1,5
► RS 44/1 MZ	230	T6	1,5

V = Electrical supply F = Fuse L = Lead section

Emissions

The emission data has been measured in the various models at maximum output, according to EN 676 standard. The NO_x emissions of RS 34-44/1 MZ models are conforming to the class 2 of EN 676.

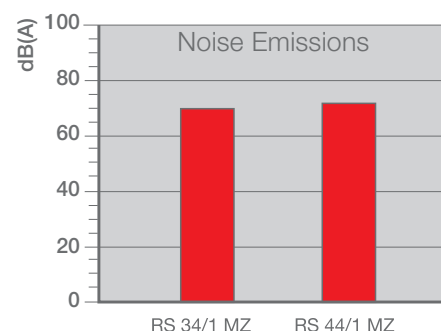
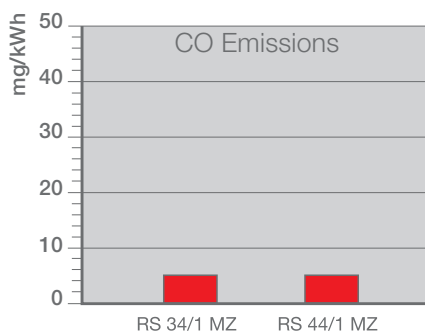
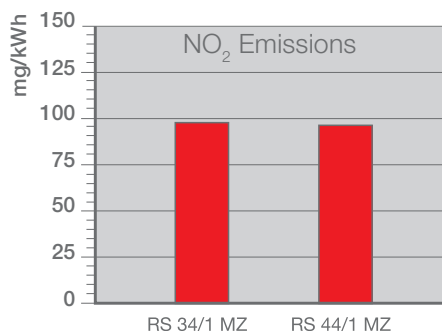

Overall Dimensions (mm)

BURNERS

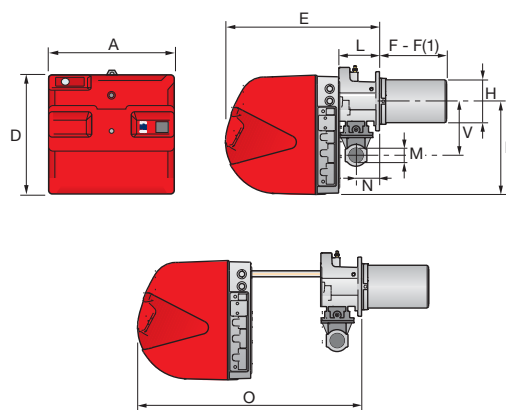

MODEL	A	D	E	F - F(1)	H	I	L	M	N	O	S	V
▶ RS 34/1 MZ	442	422	508	216 - 351	140	305	138	1"1/2	84	780	-	177
▶ RS 44/1 MZ	442	422	508	216 - 351	152	305	138	1"1/2	84	780	-	177

(1) dimension with extended head

BURNER - BOILER MOUNTING FLANGE

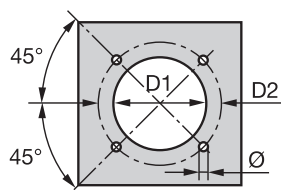

MODEL	D1	D2	Ø
▶ RS 34/1 MZ	160	224	M8
▶ RS 44/1 MZ	160	224	M8

PACKAGING

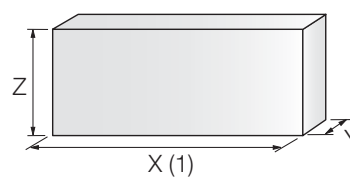

MODEL	X (1)	Y	Z	kg
▶ RS 34/1 MZ	1000	485	500	32
▶ RS 44/1 MZ	1000	485	500	33

(1) dimension with standard and extended head

Installation Description

Installation, start up and maintenance must be carried out by qualified and skilled personnel.
All operations must be performed in accordance with the technical handbook supplied with the burner.

BURNER SETTING

All the burners have slide bars, for easier installation and maintenance.

After drilling the boilerplate, using the supplied gasket as a template, dismantle the blast tube from the burner and fix it to the boiler.

Adjust the combustion head.

Fit the gas train, choosing this on the basis of the maximum output of the boiler and considering the enclosed diagrams.

Refit the burner casing to the slide bars.

Close the burner, sliding it up to the flange.

ELECTRICAL CONNECTIONS AND START UP

Make the electrical connections to the boiler following the wiring diagrams included in the instruction handbook.

Perform a first ignition calibration on the gas train.

On start up, check:

- Gas pressure at the combustion head (to max. and min. output)
- Combustion quality, in terms of unburned substances and excess air.

BURNER MAINTENANCE

The maintenance of RS/1 burners is very simple thanks to the sliding bars system that allows an easy access to the internal components.

Burner Accessories



Extended head kit

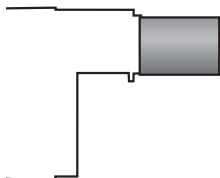

“Standard head” burners can be transformed into “extended head” versions, by using the special kit. The KITS available for the various burners, giving the original and the extended lengths, are listed below.

BURNER	'STANDARD HEAD' LENGTH (mm)	'EXTENDED HEAD' LENGTH (mm)	KIT CODE
▶ RS 34/1 MZ	216	351	3010428
▶ RS 44/1 MZ	216	351	3010429

Spacer kit



If burner head penetration into the combustion chamber needs reducing, varying thickness spacers are available, as given in the following table:

BURNER	SPACER THICKNESS S (mm)	KIT CODE
▶ RS 34/1 MZ - 44/1 MZ	90	3010095

Post-ventilation kit

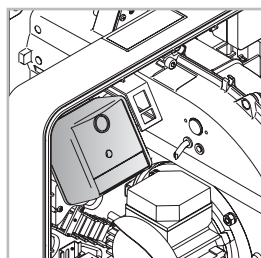

To prolong ventilation for approximately 5 seconds after opening of thermostats chain, a special kit is available.

BURNER	KIT CODE
▶ RS 34/1 MZ - 44/1 MZ	3010452

Continuous ventilation kit



If the burner requires continuous ventilation in the stages without flame, a special kit is available as given in the following table:

BURNER	KIT CODE
▶ RS 34/1 MZ - 44/1 MZ	3010449

Sound proofing box



If noise emission needs reducing even further, sound-proofing boxes are available, as given in the following table:

BURNER	BOX TYPE	AVERAGE NOISE REDUCTION [dB(A)](*)	BOX CODE
▶ RS 34/1 MZ - 44/1 MZ	C1/3	10	3010403

(*) according to EN 15036-1 standard

LPG kit



For burning LPG gas, a special kit is available to be fitted to the combustion head on the burner, as given in the following table:

BURNER	KIT CODE
▶ RS 34/1 MZ	3010423
▶ RS 44/1 MZ	3010424

Town gas kit



For burning Town gas, a special kit is available:

BURNER	KIT CODE FOR 'STANDARD HEAD' (*)	KIT CODE FOR 'EXTENDED HEAD' (*)
▶ RS 34/1 MZ	in progress	in progress
▶ RS 44/1 MZ	in progress	in progress

(*) Without CE certification

Hours counter kit

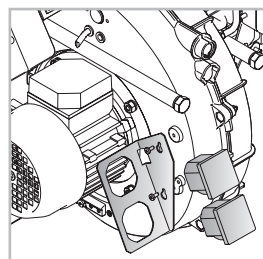

To measure the burner working time a hours counter kit is available.

BURNER	KIT CODE
▶ RS 34/1 MZ - 44/1 MZ	3010450

Ground fault interrupter kit



A "Ground fault interrupter kit" is available as a safety device for electrical system fault.

BURNER	KIT CODE
▶ RS 34/1 MZ - 44/1 MZ	3010448

Gas max pressure switch

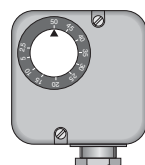

If necessary a Gas max pressure Switch kit is available and connectable to the burner electrical wiring trough Plugs & Sockets system.

BURNER	KIT CODE
▶ RS 34/1 MZ - 44/1 MZ	3010418

Volt free contact kit



A volt free contact kit is available for installation onto the burner. It can be used for a remote interface between burner operating signals. Every burner can be equipped with a single kit for a remote check of the flame presence signal and the burner lockout indication.

BURNER	KIT CODE
► RS 34/1 MZ - 44/1 MZ	3010419

PC interface kit



To connect the flame control panel to a personal computer for the transmission of operation, fault signals and detailed service information, an interface adapter with PC software are available.

BURNER	KIT CODE
► RS 34/1 MZ - 44/1 MZ	3002719

Gas Train Accessories

Adapters



When the diameter of the gas train is different from the set diameter of the burners, an adapter must be fitted between the gas train and the burner. The following table lists the adapters for various burners.

BURNER	GAS TRAIN	DIMENSIONS	ADAPTER CODE
► RS 34/1 MZ	MBD 405 - 407 - 410	3/4" 1" 1/2	3000824
	MBZRDLE 407 - 410	3/4" 1" 1/2	3000824
	MBD 420 - 420 CT	2" 1" 1/2	3000822
	MBZRDLE 420 - 420 CT	2" 1" 1/2	3000822
► RS 44/1 MZ	MBD 407 - 410	3/4" 1" 1/2	3000824
	MBZRDLE 407 - 410	3/4" 1" 1/2	3000824
	MBD 420 - 420 CT	2" 1" 1/2	3000822
	MBZRDLE 420 - 420 CT	2" 1" 1/2	3000822

Seal control kit



To test the valve seals on the gas train, a special "seal control kit" is available. The valve seal control device is compulsory (EN 676) on gas trains to burners with a maximum output over 1200 kW. The sealing control is type VPS 504.

GAS TRAIN	KIT CODE
► MBD 405 - MBD 407 - MBZRDLE 407 - MBD 410 - MBZRDLE 410 MBD 412 - MBZRDLE 412 - MBD 415 - CB 40/1	3010123
► MBZRDLE 415 - CB 40/2 - MBZRDLE 420 - CB 50/2	3010125

Specification

DESIGNATION OF SERIES

A specific index guides your choice of burner from the various models available in the RS/1 series. Below is a clear and detailed specification description of the product.

Series: R	
Fuel:	S Natural Gas
	SP LPG
	L Light oil
	LS Light oil/Methane
	N Heavy oil
Size	
Setting:	/1 Single stage
	... Two stage
	/M Modulating
Emission:	... Class 1 EN267 - EN676
	MZ Class 2 EN267 - EN676
	BLU Class 3 EN267 - EN676
	MX Class 1 EN267
	Class 3 EN676
Head length:	TC standard head
	TL extended head
Flame control system:	
	FS1 Standard (1 stop every 24 h)
	FS2 Continuous working (1 stop every 72 h)
Electrical supply to the system:	
	1/230/50 1/230V/50Hz
	1/220-230/50-60 1/220-230V/50-60Hz
	3/230/50 3/230V/50Hz
	3/400/50 3N/400V/50Hz
	3/230-400/50 3/230V/50Hz - 3N/400V/50Hz
	3/220/60 3/220V/60Hz
	3/380/60 3N/380V/60Hz
	3/220-380/60 3/220V/60Hz - 3N/380V/60Hz
	3/220-400/50-60 3/220-230V/50-60Hz
	3/380-400V/50-60Hz
Auxiliary voltage:	
	230/50-60 230V/50-60Hz
	220-230/50-60 220-230V/50-60Hz
	110/50-60 110V/50-60Hz
ID:	Differential switch

R	S	34	/1	MZ	TC	FS1	1/230/50	230/50-60	
BASIC DESIGNATION									
EXTENDED DESIGNATION									

AVAILABLE BURNER MODELS

RS 34/1 MZ	TC	FS1	1/220-230/50-60	220-230/50-60
RS 34/1 MZ	TL	FS1	1/220-230/50-60	220-230/50-60
RS 44/1 MZ	TC	FS1	1/220-230/50-60	220-230/50-60
RS 44/1 MZ	TL	FS1	1/220-230/50-60	220-230/50-60

Other versions are available on request.

PRODUCT SPECIFICATION

RS 34/1 MZ - 44/1 MZ models

Burner

Monoblock forced draught gas burner with one stage operation, fully automatic, made up of:

- Air suction circuit
- High performance fan with straight blades
- Air damper for air flow setting
- Starting motor at 2800 rpm, single-phase / 220-230V / 50-60Hz
- Combustion head, that can be set on the basis of required output, fitted with:
 - stainless steel end cone, resistant to corrosion and high temperatures
 - ignition electrodes
 - ionisation probe
 - gas distributor
 - flame stability disk
- Minimum air pressure switch stops the burner in case of insufficient air quantity at the combustion head
- Microprocessor-based flame control panel, with diagnostic functions
- Plug and socket for electrical connections accessible from the external of the cover
- Flame inspection window
- Slide bars for easier installation and maintenance
- Protection filter against radio interference
- IP X0D (IP 40) electric protection level.

Gas train

Fuel supply line, in the MULTIBLOC configuration (from a diameter of 3/4" until a diameter 2") fitted with:

- Filter
- Stabiliser
- Minimum gas pressure switch
- Safety valve
- One stage or two stage working valve with ignition gas output regulator.

Conforming to:

- 89/336 (2004/108) EC directive (electromagnetic compatibility)
- 73/23 (2006/95) EC directive (low voltage)
- 92/42/EC directive (performance)
- 90/396/EC directive (gas)
- EN 676 (gas burners).

Standard equipment:

- 1 gas train gasket
- 1 flange gasket
- 4 screws for fixing the flange
- 1 thermal screen
- 4 screws for fixing the burner flange to the boiler
- 3 plugs for electrical connection
- Instruction handbook for installation, use and maintenance
- Spare parts catalogue.

Available accessories to be ordered separately:

- Extended head kit
- Spacer kit
- Sound-proofing box
- LPG kit
- Hours counter kit
- Ground fault interrupter kit
- Gas max pressure switch
- Volt free contact kit
- Interface adapter kit
- Gas train adapter
- Seal control kit.

RIELLO s.p.A.

Via Ing. Pilade Riello, 5
37045 Legnago (VR) Italy

Tel. +39.0442.630111 - Fax +39.0442.21980

www.rielloburners.com - info@rielloburners.com

Since the Company is constantly engaged in the production improvement, the aesthetic and dimensional features, the technical data, the equipment and the accessories can be changed.
This document contains confidential and proprietary information of RIELLO S.p.A. Unless authorised, this information shall not be divulged, nor duplicated in whole or in part.



Riello Burners is a brand of Riello Group.